

SUPPLIER / MANUFACTURER:

- ✓ 1. BASIC DESIGN
- ✓ 2. DETAIL DESIGN
- ✓ 3. MATERIAL SUPPLY

- ✓ 4. FABRICATION
- ✓ 5. INSPECTION AND TESTING

- ✓ 6. FIELD ASSEMBLY
- ✓ 7. SPARE PARTS
- ✓ 8. DOCUMENTS AND DATA

MAT. SUPPLY	TESTING	DELIVERY DATE	ATTACHMENTS: AS SPECIFIED BELOW
GSFC SITE PO F'NAGAR	YES	AS PER P.O.	

S.NO.	ITEM	QTY.
1	AS-IV Vacuum Package	01 SET

- ATTACHMENTS:**
1. Process Specification for Vacuum Package (Attachment-I)
96-ASIV-SP-09010, Sheet 1 to 3 of 3, R1
 2. P&ID: (Attachment-I)
96-ASIV-AS-00002, Sht. 1 of 1, R2
96-ASIV-AS-00003, Sht. 1 of 1, R2
96-ASIV-BS-00010, Sht. 1 of 1, R3
 3. Specification for Horizontal Centrifugal pumps (Attachment-II)
 4. Specification for Electrical requirements (Attachment-III)
 5. Specification for Instrumentation requirements (Attachment-IV)
 6. General Specification for Fabricated Equipments LS-00060, Sheet 1 to 7 of 7, R1
 7. Painting Specification
SP-23001, Sheet 1 to 7 of 7, R1
 8. General Specifications for Pickling & Passivation LS-00095, Sheet 1 of 1, R0

INSPECTION BY :- M/s GSFC /TPIA

MATERIAL REQUISITION FOR NEW VACUUM PACKAGE REQUIRED FOR THE NEW AS-IV PLANT

0	04/05/2021	Issued for enquiry	<i>Parekh</i>	<i>Desai</i>
REV	DATE	DESCRIPTION	CHD.	APPD.

JOB NO:- PROJ/228



**GUJARAT STATE
FERTILIZERS & CHEMICAL LTD.
DESIGN DEPARTMENT**

MATERIAL REQUISITION					
PROJECT	UNIT	FORM	NUMBER	SHEET	REV
96	AS-IV	MR	30005	1 OF 11	0

TECHNICAL SPECIFICATIONS FOR VACUUM PACKAGE FOR NEW AS-IV PLANT

1.0 Preamble:

1.1 It is proposed to install new Vacuum Package in our new AS-IV Plant to maintain vacuum in evaporation-crystallization system of this new AS-IV Plant. This package is required in the downstream of Crystallizer-I (XD-4) and Crystallizer-II (XD-6). These specifications are drawn to define scope and technical requirements of this Vacuum Package.

2.0 Scope of Work:

2.1 The Scope of work shall include design of the equipments/ machinery of this package, submission of design calculations, detailed fabrication drawings and Quality Assurance Plan, fabrication of equipments as per approved drawings, Inspection and testing of equipment at manufacturer's works, supply of the equipments to GSFC stores, supply of final drawings and quality documents in the form of Inspection Dossier and transportation of these equipments to GSFC site. Guarantee test run of this package is to also be included in your scope.

2.2 The supplier shall also include spares as listed at clause 7.1 as part of their scope of supply.

2.3 Supplier shall submit a bar chart giving a break-up of activities like completion of engineering, drawing submission, procurement of major materials, major milestones of fabrication, final inspection, transportation, etc.

2.4 Supplier shall also inform procurement, latest manufacturing / fabrication status of equipments of this Vacuum Package on every fifteen days with site/shop photographs.

3.0 Design & Drawings :

3.1 Static equipments which are part of this new Vacuum Package shall be designed, fabricated, tested and inspected as per ASME Sec-VIII, Div-1/ TEMA (for vessels, heat exchangers).

3.2 Pumps, electrical components, instrumentation shall be designed as per Attachments-II, III & IV. Following documents are enclosed for your ready reference

- Process specification 96-ASIV-SP-09010, Sheet 1 to 3 of 3, R1 (Attachment-I)
- P&ID 96-AS-IV-AS-00002, Sht. 1 of 1, R2, 96-ASIV-AS-00003, Sht. 1 of 1, R2 and 96-ASIV-BS-00010, Sht. 1 of 1, R3 of this Vacuum Package. (Attachment-I)



GUJARAT STATE FERTILIZERS &
CHEMICALS LIMITED
DESIGN DEPARTMENT
PO: Fertilizernagar - 391750

Specifications for Vacuum Package

PROJECT	UNIT	FORM	NUMBER	SHEET	REV
96	AS-IV	MR	30005	2 of 11	0

The equipments that comprise this package are as follows:

- Condenser-I (XD-6)
- Condenser-II (XD-8)
- 2 nos. Vacuum Pumps (XP-12 A & B): One working, one standby.
- Coolers for vacuum pump circuit.
- 2 nos. Seal Pots (XD-7 A & B)
- Any other equipment required for satisfactory performance, but not listed above.

3.3 Thermal (Process), Mechanical design of the complete vacuum package (including condensers and coolers, pumps, electrical/instrumentation) shall be in the scope of supplier and shall satisfy the design conditions as mentioned in the Process specifications. The complete process design of this package to be submitted to GSFC for review.

3.4 Supplier shall submit mechanical design calculations along with detail fabrication drawing, bill of material and proposed Quality Assurance Plan (QAP) to GSFC for approval.

3.5 Equipment arrangement drawing of the whole system shall also be furnished. Tentative layout made by GSFC is attached with this requisition for your ready reference; any changes considered with respect to our layout shall be clearly indicated in your offer.

3.6 Supplier to indicate following details in their technical offer:

- All major component thicknesses of Condensers/coolers like main shell, channel shell, tubesheet, channel flanges, dish-ends, tubes etc.
- Weight and support dimensions of Condensers, seal pots and pump skids. These are required for provision of foundation by GSFC.
- List of instruments, their spares and utilities required for these.
- For pumps, supplier shall mention layout, kW rating, MOC, and make of bought out items like coupling, bearing, seal and motor.
- Tentative P&ID, process specifications and layout of all equipment / machineries with dimensions to finalize the location and required space for this package unit.

3.7 Piping connection between condensers, seal pots and pump skids shall be in GSFC scope. Interconnecting piping within pump unit (scope marked in attached P&ID) shall be in scope of supplier. MOC of piping components and flange bolting to be furnished as per ASME specifications.

3.8 Vendor to provide motor and junction box for the Pump skid. Necessary power supply arrangement from central sub-station to junction box shall be in GSFC

	GUJARAT STATE FERTILIZERS & CHEMICALS LIMITED DESIGN DEPARTMENT PO: Fertilizernagar - 391750	Specifications for Vacuum Package					
		PROJECT	UNIT	FORM	NUMBER	SHEET	REV
		96	AS-IV	MR	30005	3 of 11	0

scope. Internal wiring of the pump skid upto junction box shall be in scope of supplier.

- 3.9 Cabling for instruments to control room/DCS panel shall be in scope of GSFC. However, supplier to furnish cable details and other requirements necessary to operate each instrument clearly in technical offer.
- 3.10 Supplier shall also include 2 Years operational spare for Vacuum pumps as scope of supply. Details of the items to be considered under this is mentioned in enclosed Attachment-II
- 3.11 Supplier to quote separate supervision charges for installation of this Vacuum Package at site. GSFC shall decide regarding supervision services post order stage.
- 3.12 Suppliers shall prepare detailed shop fabrication drawings of equipments/ pumps of this Vacuum Package to meet all applicable code requirements. The drawing should contain all necessary details viz. Design data, weld joint configurations, testing requirements, component part numbers, bill of material etc. This fabrication drawing will be subject to approval of GSFC.
- 3.13 All equipments of this new Vacuum Package shall be provided with necessary arrangement for lifting / handling the equipment at site for erection.
- 3.14 General Specification LS-00060 for fabricated equipments is enclosed with this specification. Requirements of the same shall also be fulfilled.
- 3.15 General Specification for Horizontal Centrifugal pumps is enclosed with this specification (Attachment-II). Requirements of the same shall also be fulfilled.
- 3.16 General Specification for Electrical requirements is enclosed with this specification (Attachment-III). Requirements of the same shall also be fulfilled.
- 3.17 General Specification for Instrumentation requirements is enclosed with this specification (Attachment-IV). Requirements of the same shall also be fulfilled.
- 3.18 Revisions of drawings will specifically mention the change made while revising the drawing.
- 3.19 Prior to submitting offer, bidder, if required, may come down to GSFC to understand the scope of supply. In case, any difficulty is envisaged from fabrication point of view during post order stage, the same should also be discussed in person by visiting GSFC.

4.0 Materials:

4.1 The Material of Construction for Heat Exchangers shall be as follows:

	GUJARAT STATE FERTILIZERS & CHEMICALS LIMITED DESIGN DEPARTMENT PO: Fertilizernagar - 391750	Specifications for Vacuum Package					
		PROJECT	UNIT	FORM	NUMBER	SHEET	REV
		96	AS-IV	MR	30005	4 of 11	0

Sr No	Item Description	Material of Construction
1.	Shell / dished ends	SA-240 Gr TP 316L
2.	Tubes (Seamless Construction)	SA-213 Gr TP 316L
3.	Nozzle necks (Seamless)	SA 312 Gr TP 316L
4.	Nozzle flanges / Body flanges	SA 182 F 316L
5.	Saddle / bracket supports (as applicable)	Carbon Steel
6.	Gaskets	* vendor to suggest
7.	Stud/bolts with 2 nuts	SA 193 B7 / SA 194 2H

Vendor to review the MOC as per requirement of the package mentioned in attached Process specification.

4.2 The Material of Construction for vacuum pumps shall be as follows:

Sr.No.	Item Description	Material of Construction
8.	Body/ Nozzle Flange	SA-182 F-316L*
9.	Nozzle necks/ flanges	SA-312 TP316L*
10.	Pump Casing	SS-304L*
11.	Impeller	SS-316L*
12.	Base Plate	SS-316L*

*Vendor to confirm MOC.

4.3 The material of construction for electric components shall be as per enclosed Attachment- III.

4.4 The material of construction for instrument components shall be as per enclosed Attachment-IV.

4.5 Supplier shall indicate the names of the sub-suppliers they propose to consider for bought out materials like plates, pipes, flanges, gaskets, fasteners, couplings, seal etc. Material suppliers shall be reputed national/international manufacturers i.e Origin of material shall be from India, USA, Europe, Japan and Korea with all necessary material manufacturing, inspecting and testing facilities in-house. GSFC's approval for material suppliers shall be obtained. Materials of Chinese origin are not acceptable.

4.6 Materials shall be procured with all necessary test certificates as required by GSFC. GSFC/ appointed TPI shall approve material testing, Quality Assurance Plan (QAP). Inspection stamping shall be co-related with material certificates.

4.7 All bought out components / sub-ordered items shall be procured under the inspection of Supplier/ GSFC/ appointed TPI. Material Inspection / Testing Certificates duly approved by Inspection authority shall be supplied along with final documentation.

	GUJARAT STATE FERTILIZERS & CHEMICALS LIMITED DESIGN DEPARTMENT PO: Fertilizernagar - 391750	Specifications for Vacuum Package					
		PROJECT	UNIT	FORM	NUMBER	SHEET	REV
		96	AS-IV	MR	30005	5 of 11	0

5.0 Fabrication:

- 5.1 Supplier shall commence fabrication only after approval of fabrication drawings and design calculations by GSFC. Any mismatch observed during fabrication stage of equipment with respect to drawing, supplier to immediately inform GSFC and obtain clearance. Supplier should not proceed without clearance from GSFC.
- 5.2 Welding electrodes and other consumables used during fabrication shall be of approved makes like ADVANI ORLIKON, ESSAB, and D & H Schecheron. Use of any other consumables except mentioned above shall not be acceptable. In case above-mentioned make consumables are not available, supplier to take permission in written from GSFC prior to procurement of other make.
- 5.3 Necessary mock-up and testing shall be carried out to establish soundness of weld, tube to tube sheet joint load, etc. for heat exchangers in this package. Details of such mock-up tests should be submitted to GSFC. Tube to tube sheet joint shall be leak tested with air and soap solution at 2 kg/cm². Helium leak testing shall also be carried out for tube to tube sheet joint.
- 5.4 Dimensional tolerances shall be as per approved drawings. In absence of tolerances in existing equipment drawings, supplier to inform and take approval the tolerances in newly as per design codes / good engineering practice to GSFC.

6.0 Inspection & Testing:-

- 6.1 The order shall be executed including procurement of material under the inspection of M/s GSFC and appointed TPI.
- 6.2 Supplier shall inform progress of work and stages of inspection to GSFC for their perusal and deputing the inspection engineer, if required.
- 6.3 Stage and final inspection for equipment shall be carried out by GSFC/ appointed TPI at least for following stages.
- (a) Raw material testing and certification at sub-supplier's works by GSFC appointed TPI agency.
 - (b) Tubes, tube sheets, channel/ body flanges, forgings etc. shall be stage wise inspected at Manufacturer's work as per approved ITP of manufacturer under GSFC appointed TPI with EN 3.2 Certification. This ITP to be submitted to GSFC for approval and comments of GSFC to be incorporated. Other components shall be procured with minimum EN3.1 certification with necessary inspection and check testing.
 - (c) Tubes shall be inspected and tested in hydro, eddy current and PMI by GSFC appointed TPI.
 - (d) All SS components shall be IGC tested.
 - (e) Raw material identification in Supplier's workshop.
 - (f) Ultrasonic testing of tube sheets / Plates / forgings / flanges etc.



GUJARAT STATE FERTILIZERS &
CHEMICALS LIMITED
DESIGN DEPARTMENT
PO: Fertilizernagar - 391750

Specifications for Vacuum Package

PROJECT	UNIT	FORM	NUMBER	SHEET	REV
96	AS-IV	MR	30005	6 of 11	0

- (g) Welding procedure, Welder's qualification, mock-up, etc. as per specifications/code requirements.
- (h) Edge preparation, DP and dimensional check.
- (i) Alignment of weld joint set-ups.
- (j) 100 % DP test of all weld joints for root and subsequent runs including fillet joints.
- (k) Radiographic examination of finished welds.
- (l) Leak test of tube to tube sheet joint with air and soap solution at 2 kg/cm²
- (m) Hydro test for both shell and tube side.
- (n) Removal of water and dry air flushing, Painting etc.
- (o) Final Dimensional check.
- (p) Pickling and Passivation / Painting (as applicable)
- (q) For remaining details of inspection, please refer attached Annexure-II for Centrifugal pumps
- (r) Electrical components inspection and testing as per Annexure-III
- (s) Instrument components inspection and testing as per Annexure-IV
- (t) Tentative Mock up and Performance test of Vacuum Package with no load. (shop test)

6.4 After successful erection and commissioning of complete unit under supervision of supplier, performance test will be conducted at a convenient time to GSFC. This guarantee run shall be carried out by vendor for 72 Hr. as per specification submitted to vendor. Following parameters shall be monitored during this GTR:

- Vacuum of 150 mmHg (abs) generated in time period of 100 minutes.
- Noise level: 85 dB (max) at distance of one meter.
- Utility consumed by vacuum pumps.

6.5 GSFC reserves right to participate at any or all stages of inspection.

However, such approval is not relieving Supplier from their basic responsibility of fulfillment of satisfactory performance, mechanical stability and workmanship of new Desuperheater.

6.6 All stage inspection, stamping, final certification and release note duly signed by appointed TPI shall be submitted to GSFC as final documentation.

7.0 Spares:-

7.1 The following material shall be supplied in excess of the actual requirement as mentioned below (as applicable):

- (a) Studs, Bolts & Nuts - 10 % (Min. 4 nos.) for each size.
- (b) Gaskets - 3 sets for each joint.
- (c) For spares of vacuum pump and accessories, please refer attached Annexure-II for Centrifugal pumps

	GUJARAT STATE FERTILIZERS & CHEMICALS LIMITED DESIGN DEPARTMENT PO: Fertilizernagar - 391750	Specifications for Vacuum Package					
		PROJECT	UNIT	FORM	NUMBER	SHEET	REV
		96	AS-IV	MR	30005	7 of 11	0

- (d) Supplier to quote for required spares for electrical and instrument items (if any).

8.0 Documentation:-

8.1 Documents to be submitted for approval -

- (a) Design Calculations (Process and Mechanical)
- (b) Detail fabrication drawing
- (c) Quality assurance plan
- (d) NDT Procedures
- (e) Detailed layout plan of vacuum pump unit and interconnecting piping isometrics.

8.2 Supplier to furnish Operation manual of this vacuum package to GSFC for review. Comments provided by GSFC on this manual shall be incorporated by supplier.

I

8.3 Final Documentation (4 copies each) -

As final submission, supplier shall submit four sets of all "As Built" revision of drawings, bill of material etc. along with all relevant documents in the form of Inspection Dossier duly endorsed by appointed TPI. The Inspection Dossier shall include all following documents:

- (a) "As-Built" fabrication drawing along with bill of material.
- (b) Material test certificates of all components giving chemical and physical properties, heat treatment details, ultrasonic testing certificates etc.
- (c) All stage and final inspection reports including DP, radiography, ultrasonic, visual testing etc.
- (d) Copies of WPS and PQR for the job
- (e) List of supplied spares
- (f) Hydrostatic test report.
- (g) "Rub off" of final stamping by TPI.
- (h) Guarantee certificate.
- (i) Any other documents required during execution of the order.
- (j) Inspection dossier of vacuum pumps
- (k) Inspection dossier of electric components
- (l) Inspection dossier of Instrument components

8.4 Documentation for vacuum pumps, motors and accessories shall be submitted as per requirements mentioned in attached Annexure-II for Centrifugal pumps.

8.5 Documentation for electrical and instrument items shall be submitted as per requirements mentioned in attached Annexure-III and Annexure-IV respectively.

8.6 All above documents to be also submitted in soft form – CD.

	GUJARAT STATE FERTILIZERS & CHEMICALS LIMITED DESIGN DEPARTMENT PO: Fertilizernagar - 391750	Specifications for Vacuum Package					
		PROJECT	UNIT	FORM	NUMBER	SHEET	REV
		96	AS-IV	MR	30005	8 of 11	0

9.0 Painting and Pickling & Passivation:-

9.1 The equipment shall be painted for CS parts with primer and finished paint as per painting specifications SP - 23001 attached herewith. All SS parts to be pickled and passivated as per general specification LS-00095 attached herewith.

10.0 Mechanical Guarantee:-

10.1 Vendor should guarantee the satisfactory workmanship and performance of the goods for a period of 24 months from the date of dispatch or 18 months from the date of commissioning, whichever is earlier.

10.2 If during this time, goods are found by ordering authority to be structurally, mechanically or otherwise defective, the supplier shall at his own expenses furnish field supervision services and repair or replace such defective goods on the basis of F.O.R Plant site within reasonable time and without holding up of the work.

11.0 Packing & Dispatch:-

11.1 The material shall be properly cleaned and securely packed to avoid any damage during transportation. The open ends of nozzles / shell shall be properly closed / protected to avoid damage of flange facings / bevelled ends during transportation or storage at site.

11.2 After despatch of goods, supplier shall inform despatch particulars immediately by fax / mail to take care of transit insurance formalities as transit risk is to be covered by the owner.

12.0 Deviations:-

12.1 Deviations, if any with respect to mechanical design, drawings, codes & GSFC specifications / Purchase Enquiry Specifications shall be listed out clearly and highlighted in the offer with necessary clarifications. In absence of such list, it will be presumed that the offer is totally in line with MR and its attachments, without any deviation.

13.0 List of Approved vendors:-

13.1 GSFC approved fabricators of vessels and Heat exchangers

Sr. No.	FABRICATOR NAME	COUNTRY	
1.	Fabwel Engineering Corporation	INDIA	
2.	Geecy Engineering	INDIA	
3.	GMM Pfaudler	INDIA	
4.	Patels Air Temp	INDIA	
5.	Baroda Vessels & Equipments	INDIA	
6.	Anup Engineering	INDIA	

	GUJARAT STATE FERTILIZERS & CHEMICALS LIMITED DESIGN DEPARTMENT PO: Fertilizernagar - 391750	Specifications for Vacuum Package					
		PROJECT	UNIT	FORM	NUMBER	SHEET	REV
		96	AS-IV	MR	30005	9 of 11	0

7.	Gemini Engi Fab	INDIA	
8.	Ishan Equipments (For Vessels only)	INDIA	
<p>In case non receipt of offers from above fabricators, Supplier may suggest the name of other fabricators and GSFC shall review them and based on their credentials / PTR, further approval process shall be done.</p>			

13.2 GSFC approved vendors for raw materials

Sr No	VENDOR NAME	COUNTRY	
SS PLATES			
1.	JSW STAINLESS LTD.	INDIA	
2.	ACRONI	EUROPE	
3.	NIPPON STEEL & SUMITOMO METAL	JAPAN	
4.	OUTOKUMPU	GLOBAL	
5.	MANNESMANN SALZGITTER AG	EUROPE	
6.	METAL INDUSTRIAL CORPORATION	INDIA	
7.	JAY STEEL CORPORATION	INDIA	
8.	CHANDAN STEEL	INDIA	
MS PLATES			
1.	JINDAL SAW WORKS	INDIA	
2.	ESSAR STEEL	INDIA	
3.	WELSPUN STEEL	INDIA	
4.	STEEL AUTHORITY OF INDIA LIMITED	INDIA	
SS TUBES			
1.	HEAVY METAL AND TUBE	INDIA	
2.	RATNADEEP METALS & TUBES PVT. LTD.	INDIA	
3.	ASR MET TECH.	INDIA	
4.	MAXIM TUBES	INDIA	
5.	SCODA TUBES LTD.	INDIA	
6.	SHUBHLAXMI METALS & TUBES PVT. LTD	INDIA	
FORGING			
1.	C.D.ENGINEERING COMPANY	INDIA	
2.	C.D.INDUSTRIES	INDIA	
3.	GOOD LUCK ENGINEERING CO. LTD	INDIA	
4.	SANGHVI FORGING & ENGINEERING LTD	INDIA	
5.	ECHJAY INDUSTRIES PVT. LTD	INDIA	
6.	R.D. FORGE PVT. LTD	INDIA	



GUJARAT STATE FERTILIZERS &
CHEMICALS LIMITED
DESIGN DEPARTMENT
PO: Fertilizernagar - 391750

Specifications for Vacuum Package

PROJECT	UNIT	FORM	NUMBER	SHEET	REV
96	AS-IV	MR	30005	10 of 11	0

7.	CHANDAN STEEL	INDIA	
8.	LAL METAL	INDIA	
9.	METAL FORGE PVT LTD	INDIA	
10.	CHW FORGE	INDIA	

FITTINGS

1.	TEEKAY TUBES PVT. LTD.	INDIA	
2.	TUBE PRODUCTS	INDIA	
3.	SAWAN ENGINEERS	INDIA	
4.	PIPEFIT	INDIA	
5.	TOPAZ PIPING	INDIA	
6.	GUJARAT INFRA PIPES	INDIA	

GASKETS

1.	GOODRICH GASKET PVT. LTD.	INDIA	
2.	IPG ENGINEERS PVT. LTD.	INDIA	
3.	UNIKILINGER PVT. LTD.	INDIA	
4.	S P ENGINEERS	INDIA	
5.	STARFLEX SEALING INDIA PVT. LTD.	INDIA	
6.	HEM GASKET	INDIA	

In case non receipt of offers for tubes / forgings / pipes from above vendors, Supplier may suggest the name of other vendors and GSFC shall review the vendor and based on credentials / PTR further approval process shall be done.

For Plate Material, Supplier to suggest the name of plate manufacturer / traders (in case not available from manufacturer) to GSFC and should take approval before placing the PO.

Origin of raw material used for manufacturing should be Non-Chinese origin for all components. Supplier to take care while placing enquiry / PO.



GUJARAT STATE FERTILIZERS &
CHEMICALS LIMITED
DESIGN DEPARTMENT
PO: Fertilizernagar - 391750

Specifications for Vacuum Package

PROJECT	UNIT	FORM	NUMBER	SHEET	REV
96	AS-IV	MR	30005	11 of 11	0

ATTACHMENT-I

VACUUM PUMP PACKAGE UNIT

										R	
A GENERAL											
1	ITEM NO.	XP-12									
2	NAME	Vacuum Pump									
3	NO. REQUIRED	Working: One Standby: One Spare : None Total: Two									
4	SERVICE	To maintain vacuum in evaporation-crystallization system (XD-1/ XD-4 / XD-6).									
5	LOCATION	Downstream of crystallizers-I (XD-4) & II (XD-6).									
6	TYPE	● Horizontal (Water Ring Type Rotary Vacuum Pump - Non Jacketed) ○ Vertical									
7	OPERATION	● Continuous ○ Intermittent									
B FLUID CHARACTERISTICS AND OPERATING CONDITION											
		Unit									
1	NAME		Ammonia rich water vapour + Air								
2	CONDENSABLES	Kg/Hr	~22000	(See Note 2)							
3	NON CONDENSABLES	Kg/Hr	~60								
4	OPERATING TEMPERATURE	°C	Normal: ~60	Maximum: -							
5	OPERATING PRESSURE	mm Hg abs	150 / *								
6	SYSTEM VOLUME	m ³	450								
7	EVACUATION TIME	min	100								
8	DENSITY AT OPERATING TEMPERATURE	Kg/m ³	~0.131								
9	VISCOSITY	cP	~0.011								
10	VAPOUR PRESSURE	Kg/cm ² a	~0.32								
11	POUR POINT	°C	-								
12	SOLID / SIZE AND CONTENT	○ Yes Size: - (% by wt) ● No									
13	NATURE OF FLUID	● Toxic ○ Hazardous ● Corrosive ○ Flammable ○ Explosive ○ Others									
14	CAPACITY	m ³ /hr	Normal: *	Minimum: -	Maximum: -	Rated: -	(See Note 2)				
15	SUCTION PRESSURE	mm HG	Normal: *	Minimum: -	Maximum: -						
16	DISCHARGE PRESSURE	Kg/cm ² g	Normal: Atm.	Maximum: -							
17	DIFFERENTIAL HEAD	mmHg	Normal: *	Shut-off: -							
18	NPSH	m of LC	Available: -	Required: *							
19	PUMP EFFICIENCY AT OPERATING POINT	%	*	(See Note 3)							
20	HEIGHT OF THE TANK FROM WHERE PUMP TAKES SUCTION	m	-								
C CONSTRUCTION FEATURES & MATERIAL OF CONSTRUCTION											
1 IMPELLER DETAILS											
(a)	TYPE	○ Open ○ Semi Open ○ Closed / *									
(b)	DIAMETER	mm	Rated: *	Maximum.: *	Minimum.: *						
(c)	POWER REF.TO RATED IMP.	KW	*								
2 SEALING ARRANGEMENT											
(a)	SEALING FLUID	● Self-sealing ○ External Fluid: Name: DMW / * (See Note 5)									
		Pressure: 2/* Kg/cm ² g Temperature: Ambient/* °C									
3	LINE / NOZZLE SIZE	inches / *	Suction: *	Discharge: *							
4	MATERIAL OF CONSTRUCTION	Casing: SS-304L /* Impeller: SS-316L /* Base Plate : SS-304L									
5	NRV AVAILABLE IN PUMP DISCHARGE	● Yes ○ No									
6	POSSIBILITY OF REVERSE ROTATION OF IMPELLER	○ Yes ● No									
D DRIVER DETAILS											
		● Motor ○ Turbine									
1	TYPE	● Ordinary ○ Class (○ I ○ II), Zone (○ I ○ II)									
2	RATING	KW	*								
3	SPEED	rpm	*								
4	POWER TRANSMISSION	Direct									
GUJARAT STATE FERTILIZERS & CHEMICALS LTD.											
(DESIGN DEPARTMENT)											
				DGN:	NRT / SSG	PROCESS SPECIFICATION FOR VACUUM PUMP					
				CHD:	SRP						
				APD:	VNP						
				ITEM NO : XP-12			SCHEME: New 400 MTPD Ammonium Sulfate Plant at Baroda Unit (BU)				
1	03/03/21	Revised as marked	SRP	VNP	JOB NO.: Proj/228			Plant : AS-IV Plant			
0	16/07/20	Issued for Est. / Proc.	SRP	VNP	PROJ	UNIT	FORM	NUMBER	SHEET	R	
R	DATE	DESCRIPTION	CHD	APD	96	AS-IV	SP	09010	1 OF 2	1	

VACUUM PUMP PACKAGE UNIT

		Unit			R						
E	<u>PAINTING</u>										
1	FOR PARTS HAVING OPERATING TEMP UP TO 75 °C :			<input type="radio"/> Applicable <input checked="" type="radio"/> Non Applicable Area <input type="radio"/> Corrosive <input type="radio"/> Non Corrosive							
(a)	PRIMER			At least one coat of following <input type="radio"/> P1: Zinc Chromate/ Zinc phosphate pigmented in alkyd/phenolic media <input type="radio"/> P2: Zinc Chromate/ Zinc phosphate pigmented in epoxy <input type="radio"/> P3: Red oxide-Zinc chromate pigmented in alkyd/phenolic media OR <input type="radio"/> P4: Metallic Zinc pigmented in epoxy Dry film thickness : 1 -1.5 mills minimum.							
(b)	FINISHING PAINT			At least two coats of following <input type="radio"/> F1: Synthetic enamel <input type="radio"/> F2: Epoxy paint <input type="radio"/> F3: Coal tar epoxy OR <input type="radio"/> F4: Chlorinated Rubber paint Dry film Thickness : 5.0 mills minimum							
2	FOR PARTS HAVING OPERATING TEMP ABOVE 75 °C:			<input type="radio"/> Applicable <input checked="" type="radio"/> Non Applicable Area <input type="radio"/> Corrosive <input type="radio"/> Non Corrosive							
(a)	PRIMER			Not required							
(b)	FINISHING PAINT			F5 : Aluminum paint suitable for operating temperature Dry film Thickness : 5.0 mills minimum							
F	<u>ACCESSORIES</u>										
1	PRIMING			<input type="radio"/> Yes <input checked="" type="radio"/> No							
2	SAFETY VALVE AT DISCHARGE			<input type="radio"/> Yes <input checked="" type="radio"/> No							
3	PULSATION DAMPENER			<input type="radio"/> Yes <input checked="" type="radio"/> No							
4	HEATING ARRANGEMENT FOR PUMP			<input type="radio"/> Steam jacketting <input type="radio"/> Hot water jacketting <input type="radio"/> Steam tracing <input checked="" type="radio"/> Not required							
5	INSULATION			<input type="radio"/> Yes <input checked="" type="radio"/> No							
(a)	TYPE			<input type="radio"/> Hot <input type="radio"/> Cold							
(b)	MATERIAL			<input type="radio"/> Mineral wool <input type="radio"/> EPS <input type="radio"/> PUF							
(c)	THICKNESS	mm		-							
G	<u>INSTRUMENTATION & CONTROL</u>										
1	PUMP RUNNING INDICATION			<input type="radio"/> Local <input type="radio"/> Not Required <input checked="" type="radio"/> On DCS							
2	EMERGENCY STOP PUSH BUTTON			<input checked="" type="radio"/> Local <input type="radio"/> On DCS <input type="radio"/> Not Required							
3	AMPERE READING			<input checked="" type="radio"/> Local <input checked="" type="radio"/> On DCS <input type="radio"/> Not Required	△						
NOTES:											
1	Data marked as '*' to be indicated / confirmed by vendor.										
2	Total Vapour load from system is mentioned i.e. at inlet of primary condensers of both crystallizers considered in parallel operation.										
3	Higher efficiency of pump is preferred.										
4	Any part of Copper & its alloys in contact with process fluid is not acceptable.										
5	Automatic drain valve for sealing fluid to be provided										
6	1/2" dia coupling on pump to be provided for installation of Pressure Gauge.										
7	Noise level : 85 dB (max.) at distance of one meter.										
8	Vendor to consider storage vessel and cooler for solvent circulation.										
9	Vendor to consider provision of primary condensers to condense vapours of Crystallizer-I & Crystallizer-II along with provision of a common new seal pot for condensers.										
GUJARAT STATE FERTILIZERS & CHEMICALS LTD.											
(DESIGN DEPARTMENT)											
				DGN: NRT / SSG	PROCESS SPECIFICATION FOR VACUUM PUMP						
				CHD: SRP							
				APD: VNP							
				ITEM NO : XP-12	SCHEME: New 400 MTPD Ammonium Sulfate Plant at Baroda Unit (BU)						
1	03/03/21	Revised as marked	△	SRP	VNP	JOB NO.: Proj/228	Plant : AS-IV Plant				
0	16/07/20	Issued for Est. / Proc.		SRP	VNP	PROJ	UNIT	FORM	NUMBER	SHEET	R
R	DATE	DESCRIPTION		CHD	APD	96	AS-IV	S P	09010	2 OF 2	1

(1) AMMONIA SPARGER DETAILS FOR XD-1

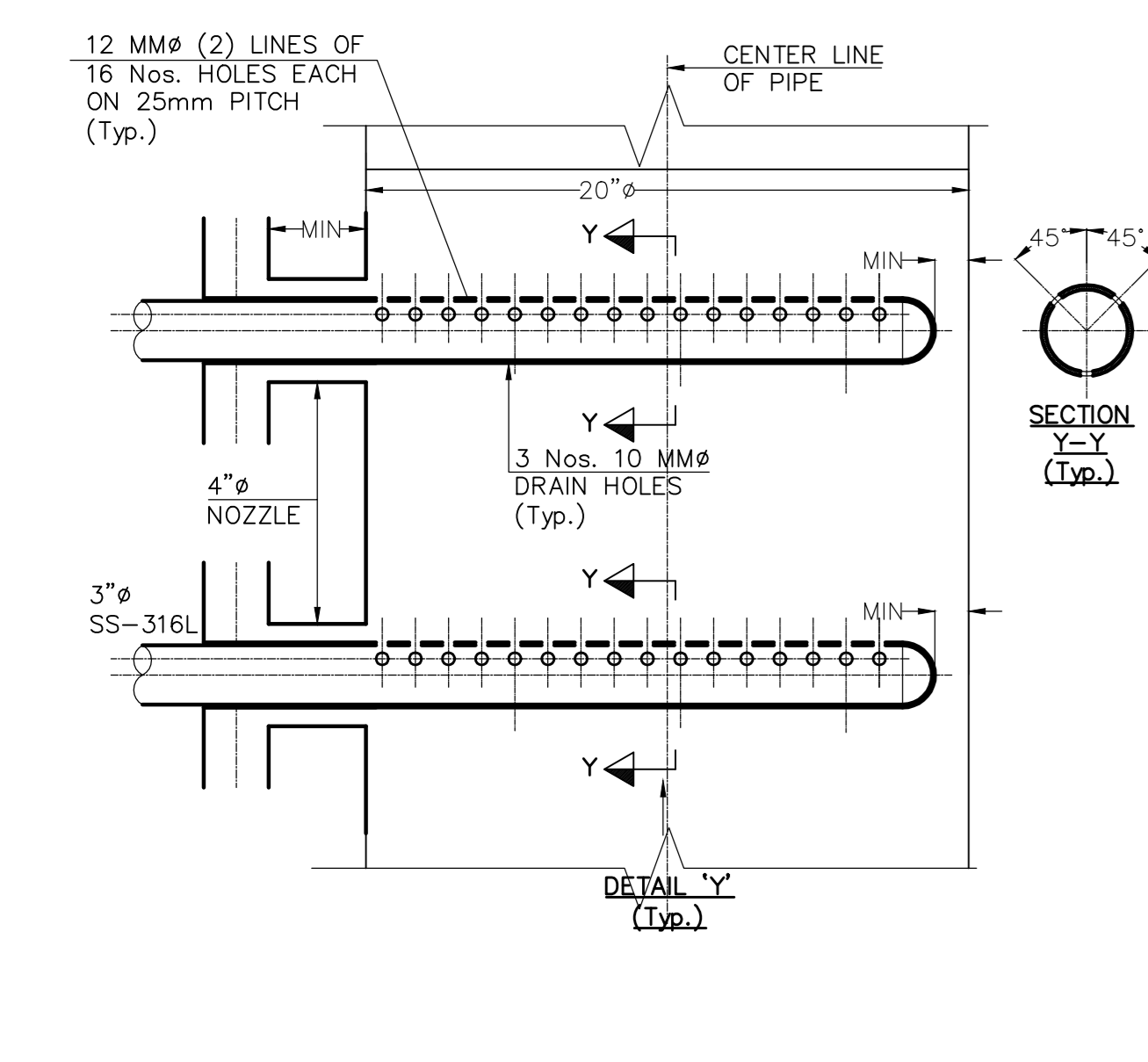

(2) SULFURIC ACID SPARGER DETAILS FOR XD-1

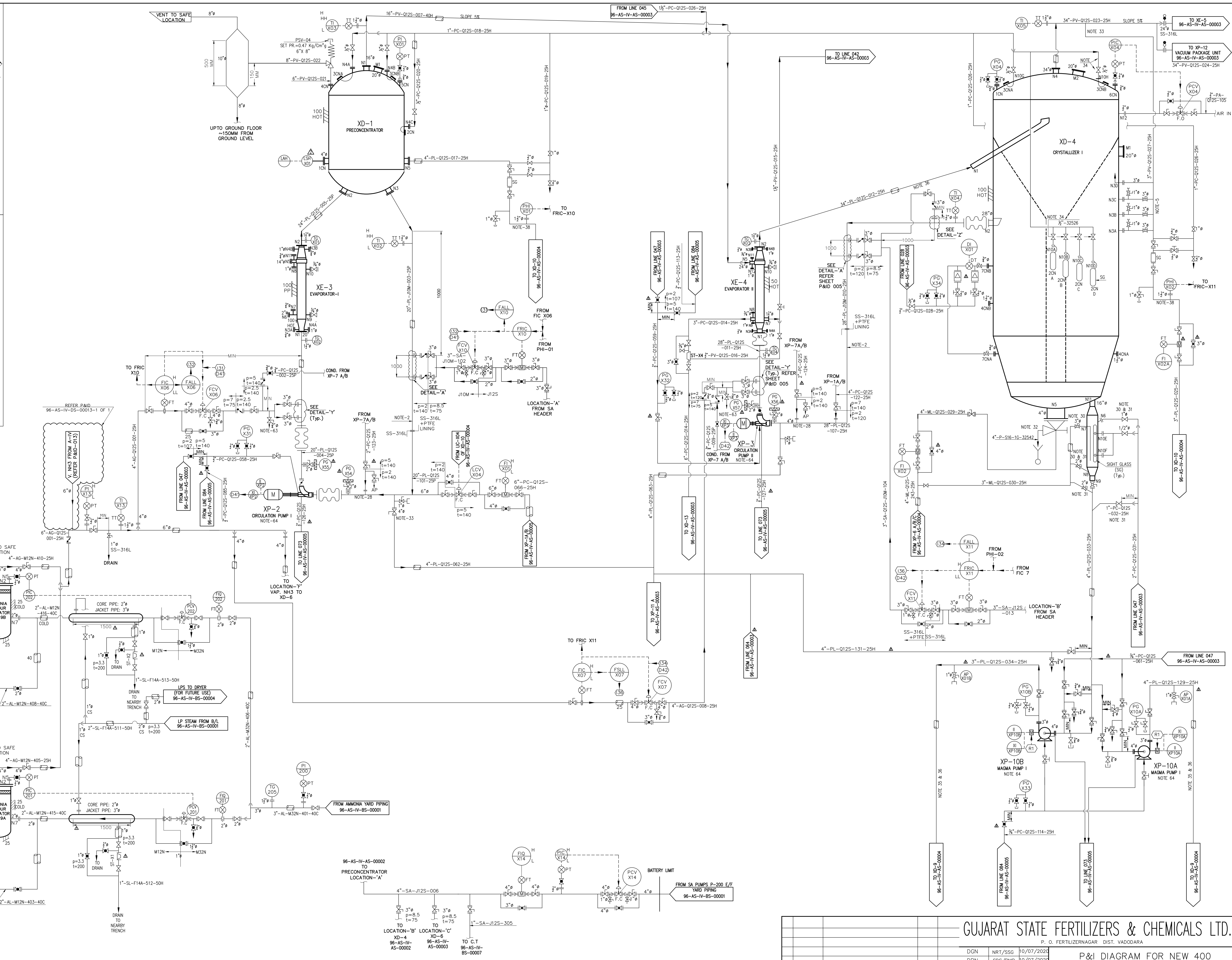
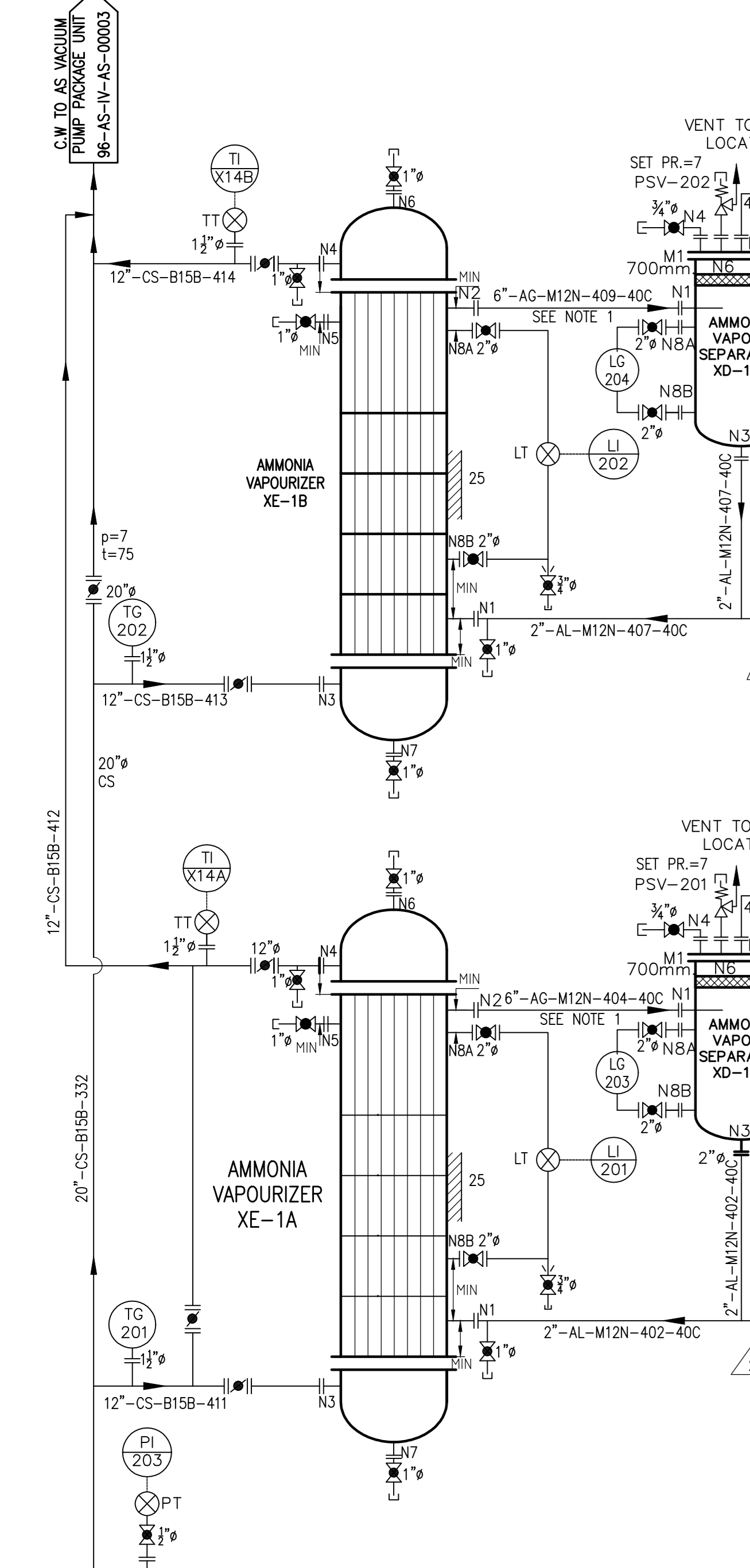
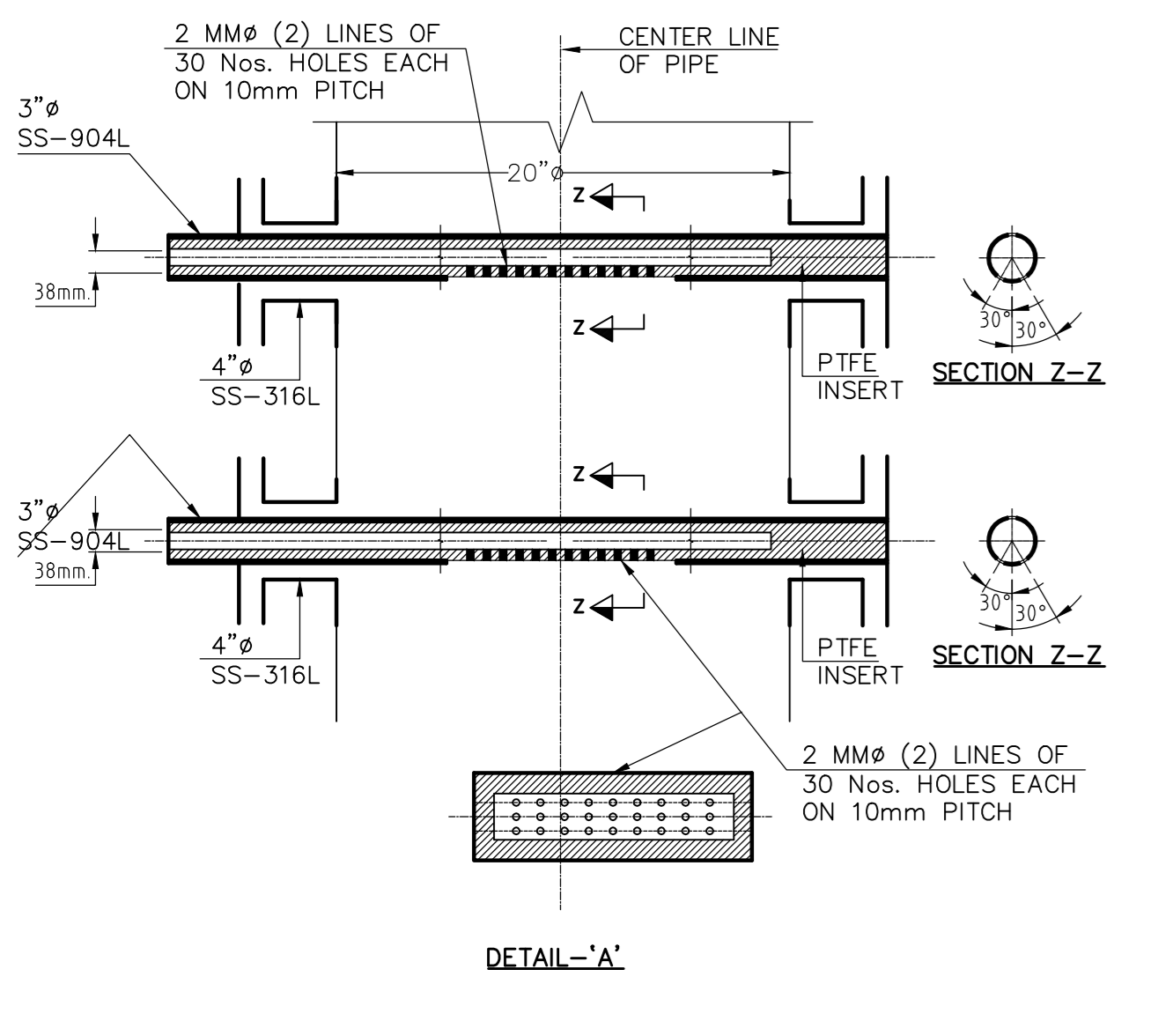

ATTACHMENT-I

		GUJARAT STATE FERTILIZERS & CHEMICALS LTD.		P. O. FERTILIZERSAGAR DIST. VADODARA	
		DGN		NRT/SSG	10/07/2020
		DRN		SDS/BMP	10/07/2020
		CHD		SRP	16/07/2020
		APD		WNP	16/07/2020
		SCALE: - NTS			
2 09/03/2021		REVISED AS MARKED ▲			
1 14/12/2020		REVISED AS MARKED ▲			
0 12/08/2020		ISSUED FOR EST./DET. ENGG.			
REV	DATE	DESCRIPTION	CHD	APD	SRP
			DESIGN DEPARTMENT		DRAWING NUMBER
			JOB NO: -PROJ/228		SHEET
			9 6 AS IV AS 00 00 0 0 2 1		REV
			PROJ UNIT FORM CLASS NUMBER		1 2

P&I DIAGRAM FOR NEW 400 MTPD AMMONIUM SULPHAT PLANT AT BARODA UNIT

ATTACHMENT-I

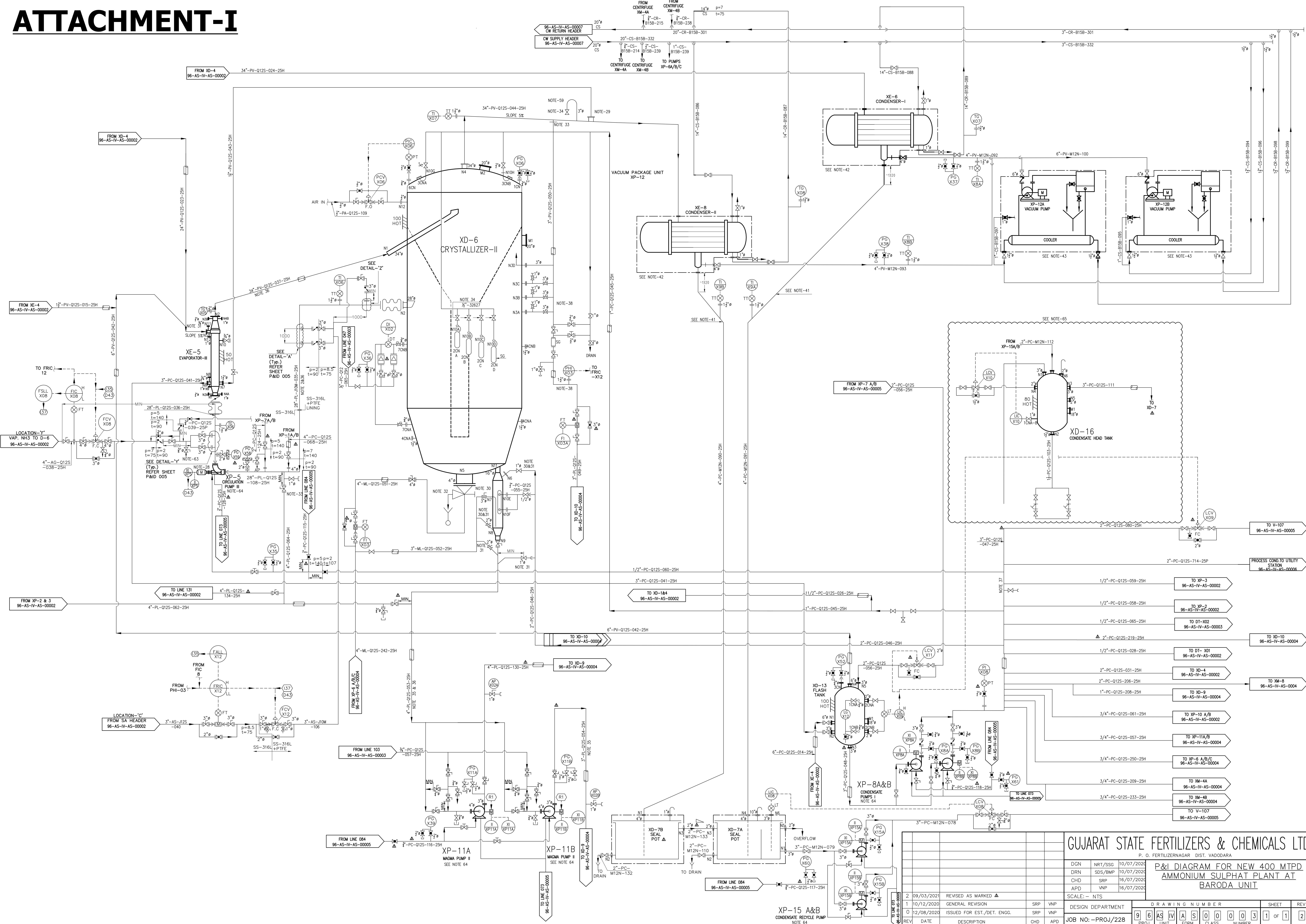

GUJARAT STATE FERTILIZERS & CHEMICALS LTD.
P. O. FERTILIZERNAGAR DIST. VADODARA

P&I DIAGRAM FOR NEW 400 MTPD AMMONIUM SULPHAT PLANT AT BARODA UNIT

DGN	NRT/SSG	10/07/2020	SCALE: - NTS	
DRN	SDS/BMP	10/07/2020	SRP	VNP
CHD	SRP	16/07/2020	SRP	VNP
APD	WNP	16/07/2020	CHD	APD

REV	DATE	DESCRIPTION	CHD	APD	SRP	VNP	CHD	APD
2	09/03/2021	REVISED AS MARKED ▲						
1	10/12/2020	GENERAL REVISION						
0	12/08/2020	ISSUED FOR EST./DET. ENGG.						

JOB NO: -PROJ/228		DESIGN DEPARTMENT		DRAWING NUMBER		SHEET		REV	
9	6	AS	IV	AS	00	00	00	3	1
PROJ	UNIT	FORM	CLASS	NUMBER			1		2

NOTES FOR P&ID NO 96-AS-IV-AS-00002 TO 005:-

- OUTLET LINE TO BE PROVIDED WITH NO ELEVATION CHANGE FROM AMMONIA VAPORIZERS (XE-1A/B) TO AMMONIA SEPARATOR (XD-19A/B).
- PTFE LINING OF 3MM THK. TO BE PROVIDED FROM IN VERTICAL SUCTION PORTION OF XP-2,3,5 OF ~3500MM LENGTH.
- INSULATION SHOWN ON PIPES & EQUIPMENTS TO BE OF HOT TYPE MINERAL WOOL / COLD TYPE EPS UNLESS OTHERWISE SPECIFIED.
- ONLY RELEVANT DETAILS OF EXISTING WORK IS SHOWN IN THIS P & I DIAGRAM.
- ALL PIPING, FITTINGS & VALVES TO BE CONSIDERED OF SS-316 UNLESS OTHERWISE SPECIFIED.
- ALL BUTTERFLY VALVES TO BE PROVIDED OF TIGHT SHUTOFF TYPE.
- △7. DRAIN LINE WITH VALVE TO BE PROVIDED ON ALL 'U' LOOP OF ACID LINES AND SAME TO BE EXTENDED UPTO NEARBY EFFLUENT LINE.
- VALVES AND INSTRUMENTS TO BE PROVIDED AT APPROACHABLE ELEVATION.
- LINE SIZE OF CONTROL VALVE AND INSTRUMENTATION SHOWN ARE TENTATIVE. SAME SHALL BE CONFIRMED BASED ON VENDOR OFFER.
- AT PRESENT I.A AIR IS CONSIDERED AS FLUSHING MEDIA. LINE SIZE INDICATED FOR I.A IS TENTATIVE. BASED ON VENDOR REQUIREMENT FLUSHING MEDIA TYPE & LINE SIZE WILL BE REVIEWED, IF REQUIRED.
- SAMPLE POINT LOCATION & SIZE SHOWN IS TENTATIVE. BASED ON VENDOR REQUIREMENT LOCATION & SIZE WILL BE REVIEWED, IF REQUIRED.
- AIR CONDITIONER, EXHAUST FAN, PROVISION OF DEDICATED AREA FOR KEEPING CALIBRATION EQUIPMENTS ETC. ARE TO BE PROVIDED BASED ON VENDOR REQUIREMENT IN PROPOSED ANALYZER ROOM.
- TOLERANCES FOR NOZZLE ORIENTATION SHOULD BE MINIMUM, PREFERABLY ZERO.
- INSULATION / HEATING ARRANGEMENT TO BE PROVIDED BY VENDOR IN SAMPLE TUBING, IF REQUIRED.
- MOC OF TUBING IS CONSIDERED AS SS-316. SUITABILITY OF THE SAME IS TO BE CONFIRMED BY ANALYZER VENDOR.
- INDICATION OF ANALYZERS ARE TO BE PROVIDED IN ANALYZER NEW SHELTER ROOM PC, DCS/PC IN CONTROL ROOM (WITH AUDIO VISUAL ALARM), PC OF CENTRAL MONITORING SYSTEM (OF EC DEPT. WITH VISUAL ALARM) FOR FURTHER TRANSMISSION TO GPCB/ CPCB WEB SITE AND AT COMPANY GATE INDICATION.
- IMPACT OF THERMOWELL ON FLOW/VELOCITY MEASUREMENT TO BE CONFIRMED BY INSTRUMENT DEPARTMENT. FURTHER, EC DEPTT. TO OPINE FOR THE SAME BASED ON THE INSTALLATIONS AVAILABLE WITH PFER INDUSTRY.
- VALVES ON INSTRUMENT AIR LINE FOR FLUSHING TO BE PROVIDED NEAR STACK ON GROUND LEVEL.
- LENGTH OF NOZZLE EXTENSION TO BE DECIDED BASED ON THE CONFIRMATION FROM INSTRUMENT DEPARTMENT.
- DISTANCE TO BE KEPT MINIMUM 8 TIMES DIAMETER OF STACK.
- ANALYZER NOZZLES FOR OMS SHALL NOT BE IN SAME VERTICAL PLANE AS PER STATUTORY GUIDELINES.
- △22. No. SPM FLOW, TEMPERATURE & PRESSURE DATA TO BE DISPLAYED IN COMMON PLANT PC, CENTRAL MONITORING STATION, CPCB/ GPCB WEB SITE & DCS.
- ALL INLET & OUTLET PIPING LINE SIZE OF PROCESS & UTILITIES TO CENTRIFUGE & DRYER FURNACE SHALL VARY BASED ON VENDOR OFFER. SAME SHALL BE CONFIRMED BASED ON VENDOR OFFER.
- SAFFTY SHOWER TO BE PROVIDED NEAR CENTRIFUGE (XM-4 A/B).
- CORIOLIS TYPE DENSITY METER & MAGNETIC FLOW METER TO BE INSTALLED IN VERTICAL LINE ONLY, HAVING FLOW IN UPWARD DIRECTION. NECESSARY PIPING MODIFICATION TO BE CARRIED OUT, IF REQUIRED.
- TAPPING SIZES FOR INSTRUMENTS AND HOOK-UP DRAWINGS FOR THE SAME TO BE FURNISHED BY INSTRUMENT ENGINEER.
- ALL THE DIMENSIONS ARE IN MM UNLESS OTHERWISE SPECIFIED.
- PIPE SPOOL FOR PUMP MAINTENANCE.
- CONNECTION MUST BE ON THE TOP SIDE OF THE VAPOR LINE.
- VALVE AT MIN. DISTANCE FROM VESSEL.
- CONNECTION ENTERING AT 45° TO VERTICAL.
- PROVIDE PLUNGER RAM TYPE VALVE.
- CONNECTION MUST BE ON THE BOTTOM SIDE OF THE LINE.
- TIGHT SHUT OFF REQUIRED.
- MIN. SLOPE 30° FLLBOWS R=6d, PIPE TO BE RUN BY SHORTEST POSSIBLE ROUTE AT MAX POSSIBLE SLOPE.
- LINES CONTAINING CRYSTALS ROOT PATHS OF PIPE JOINTS ARGON ARC WELDED AND GRINDED ON INNER SURFACE WHERE ACCESSIBLE.
- THIS LINE TO BE FITTED WITH 1"Ø HOSE CONNECTION ON EVERY FLOOR.
- PHI TO BE PROVIDED ON THE HORIZONTAL LINE.
- DRAIN LINE FOR LIQUID AMMONIA SERVICE TO BE EXTENDED UPTO NEAREST TRENCH.
- △40. USING FLEXIBLE TUBES WITH FLANGED ENDS LINES 062 AND 063 CAN BE CONNECTED TO THE MAGMA PUMP XP-11 WHICH IS NOT IN OPERATION.
- THIS LINE IS TO BE ROUTED VERTICALLY DOWNWARDS WITHOUT BENDS. INCASE ROUTING REQUIRES BENDS THEN 45° BENDS SHOULD BE USED.
- LINE SIZES SHOWN ARE TENTATIVE BASED ON PRELIMINARY VENDOR OFFER. SAME ARE SUBJECT TO CHANGES BASED ON FINAL VENDOR OFFER.
- LOCATION OF VACUUM PUMP UNIT SHALL BE FINALIZED BY VENDOR.
- △44. DISTRIBUTOR OUTLET PIPE TO BE CONSIDERED IDENTICAL TO CENTRIFUGE INLET NOZZLE SIZE AND TO BE KEPT IN VERTICAL ORIENTATION ONLY.
- FLEXIBLE JOINTS SUPPLIED WITH CENTRIFUGE.
- ROUTINGS OF PIPING SHOWN ARE TENTATIVE AND ARE TO BE FINALISED DURING DETAILED ENGINEERING BY PIPING & CIVIL GROUPS.
- CORROSION ALLOWANCE FOR SS PIPING TO BE CONSIDERED AS 1/32", FOR CS PIPING TO BE CONSIDERED AS 1/16"(3MM FOR COOLING WATER LINES, CONDENSATE LINES).
- SUCTION AND DISCHARGE VALVES FOR THE PUMPS TO BE LOCATED NEAREST TO THE PUMPS AND NECESSARY REDUCERS TO BE PROVIDED BY PIPING. REDUCERS AT SUCTION OF PUMPS TO BE ECCENTRIC TYPE.
- ALL CS PIPES, FITTINGS, VALVES AND SURFACES TO BE PAINTED AS PER LATEST REVISION OF SPECIFICATIONS OF PAINTING (SPECIFICATION NO. SP-23001) CONSIDERING THE AREA AS CORROSIVE FOR OPERATING TEMPERATURE BELOW 75°C.
- ALL INSULATED CS LINES WITH HOT INSULATION TO BE PAINTED WITH ALUMINUM PAINT SUITABLE TO THE OPERATING TEMPERATURE PRIOR TO INSULATION CONFORMING TO LATEST REVISION OF SPECIFICATIONS FOR PAINTING SPECIFICATION NO. SP-23001.
- ALL PIPELINES HAVING COLD INSULATION TO BE PAINTED WITH PRIMER AS PER LATEST REVISION OF SPECIFICATION FOR PAINTING SPECIFICATION NO. SP-23001.
- STEAM LINES TO BE PROVIDED WITH STEAM TRAPS AT REGULAR INTERVALS AND AT LOWEST ELEVATION AT EVERY CHANGE IN ELEVATION. TAPPINGS FOR STEAM TRAP TO BE TAKEN AT LOWEST ELEVATION & FROM BOTTOM OF MAIN HEADER. INSULATION OF SUITABLE THICKNESS TO BE PROVIDED ON LINE UP TO STEAM TRAP & BYPASS ISOLATION VALVE. TO PREVENT HEAT LOSSES. STEAM TRAP DRAIN TO BE EXTENDED UP TO GROUND FLOOR.
- ALL SUB TAPPINGS FOR LIQUID LINES TO BE TAKEN FROM THE BOTTOM OF MAIN HEADER.
- ALL SUB TAPPINGS OF STEAM LINES BE TAKEN FROM TOP OF THE HEADER OR SIDE IF THE EARLIER ONE IS NOT PRACTICABLE.
- ALL FLANGE JOINTS FOR SULPHURIC ACID & OLEUM SERVICE TO BE PROVIDED WITH FLANGE GUARDS.
- ALL PIPING, FITTINGS & VALVES FOR SULPHURIC ACID & OLEUM SERVICE TO BE OF CS SCH. - 80 / SS-316.
- EXTERNAL SURFACE OF NG LINE SHALL BE COATED WITH COLD APPLIED ANTI-CORROSIVE TAPE OF YELLOW COLOR FOR PROTECTION AGAINST ATMOSPHERIC CORROSION AS PER STANDARD.
- ALL LIQUID AMMONIA VALVES TO BE OF BELLOW SEAL VALVES TYPE AND ALL VAPOR AMMONIA VALVES TO BE OF FUGITIVE EMISSION FREE TYPE.
- VACUUM RELEASE AT SAFE LOCATION. OPEN END PROTECTED SUCKING IN OF PARTICLES.
- MINIMUM SLOPE 2% FOR ALL LIQUID PRODUCT LINES, ELBOWS R=6D.
- △61. LOCATION OF PUMPS TO BE KEPT UNDER HOLD. SAME SHALL BE FINALIZED AT LATER STAGE. NEW SA PUMPS TO BE LOCATED ON EAST OF EXISTING PUMP P-2060B. EXTENSION OF SHED TO BE CONSIDERED. EXISTING PRODUCT ACID LINE FROM PLANT CONNECTED TO P-2060A/B SUCTION HEADER TO BE CONSIDERED FOR REMOVAL.
- △62. ALL FLUSHING LINE TAPPINGS TO BE PROVIDED FROM TOP ONLY.
- △63. DRAIN CONNECTION FOR FLUSHING OF AMMONIA LINES TO BE PROVIDED FROM SIDE.
- △64. ROTAMETER IF REQUIRED IN INDIVIDUAL SEALING LINE OF PUMPS, TO BE CONSIDERED UNDER VENDOR SCOPE.
- △65. SEAL WATER HEAD TANK (XD-16) TO BE DELETED AS SEPARATE SEALING WATER TANK WITH PUMPS (XD-20 AND XP-20 A/B) ARE CONSIDERED.
- △66. FOUR TANGENTIAL NOZZLES TO BE PROVIDED ON TOP INLET CYLINDRICAL PORTION INPLACE OF TWO TANGENTIAL NOZZLES.
- △67. EPOXY LINING TO BE PROVIDED AT GROUND FLOOR, CENTRIFUGE FLOOR, DECANTER FLOOR AND COLUMNS IN PLANT BUILDING. ALL RCC STRUCTURE WILL BE EPOXY LINED/ ACID BRICK LINED.
- △68. CLOTH BAG FILTER SHALL BE PROVIDED ON TOP OF HOPPERS TO PREVENT DUST CARRYOVER.

△ ELECTRICAL INSTRUMENTATION INTERLOCK DESCRIPTION

INT.NO	EQUIPMENT NO.	CAUSES	CONSEQUENCES TO STOP	
R1	XM-8	RUNNING INDICATION (OFF)	XP-10A OR XP-10B	STOP
			XP-11A OR XP-11B	STOP
R2	XCO-3	RUNNING INDICATION (OFF)	XM-8	STOP
			XM-4A OR XM-4B	STOP
R3	XM-5	RUNNING INDICATION (OFF)	XCO-3	STOP
R4	XCO-4	RUNNING INDICATION (OFF)	XM-5	STOP
R5	XM-10	RUNNING INDICATION (OFF)	XCO-4	STOP
R6	XCO-5	RUNNING INDICATION (OFF)	XM-10	STOP
R8	XM-4A1	RUNNING INDICATION (OFF)	XM-4A	STOP
R9	XM-4B-1	RUNNING INDICATION (OFF)	XM-4B	STOP
R10	XM-4A & XM-4B	RUNNING INDICATION (OFF)	XM-8	STOP
R12	XCO-6 & XCO-8	RUNNING INDICATION (OFF)	XCO-5	STOP
R13	XCO-9	RUNNING INDICATION (OFF)	XM-11	STOP
R14	ZIA AND LSH-800 A	POSITION (A) AND LEVEL-800A (HIGH)	XCO-6	STOP
R15	XCO-6	RUNNING INDICATION (OFF)	XCO-9	STOP
R16	ZIB AND LSH-800 B	POSITION (B) AND LEVEL-800B (HIGH)	XCO-6	STOP
R17	XM-11	RUNNING INDICATION (OFF)	XCO-7	STOP
R18	XCO-7	RUNNING INDICATION (OFF)	RAV-01	STOP

SYMBOLS:-

- GATE VALVE
- GLOBE VALVE
- FOOT VALVE
- BUTTERFLY VALVE
- BALL VALVE
- PLUG VALVE
- NEEDLE VALVE
- CONTROL VALVE
- NRV
- STEAM TRAP
- HOSE CONNECTION
- ROTA METER
- DIAPHRAGM
- NEW WORK
- EXISTING WORK
- WORK TO BE REMOVED AND RECOVERED
- EXPANSION BELOW
- STRAINER
- MAGNETIC FLOW METER
- SIGHT GLASS (SG)
- SPECTACLE BLIND
- DRAIN
- MANUAL TYPE DIVERTER
- VENDOR'S SCOPE
- SAFETY VALVE (PSV)
- INSTRUMENTATION
- ANGLE VALVE
- MOTOR
- INSULATION
- ANALYSING POINT
- $p =$ DESIGN PRESSURE Kg/Cm² g
- $t =$ DESIGN TEMPERATURE °C.
- TRANSMITTER
- INDICATION ON DCS
- LOCAL INSTRUMENT
- INSTRUMENT WITH HIGH & LOW ALARM
- CENTRIFUGAL PUMP
- AXIAL PUMP
- MOTORIZED ROTARY VALVE
- DAMPER VALVE (FLAPPER)

INSTRUMENT ABBREVIATIONS

- FI FLOW INDICATOR
- PI PRESSURE INDICATOR
- TI TEMPERATURE INDICATOR
- LI LEVEL INDICATOR
- TT TEMPERATURE TRANSMITTER
- FT FLOW TRANSMITTER
- LT LEVEL TRANSMITTER
- PT PRESSURE TRANSMITTER
- PAHH HIGH HIGH PRESSURE ALARM
- TAHH HIGH HIGH TEMPERATURE ALARM
- FALL LOW LOW FLOW ALARM
- LAH HIGH LEVEL ALARM
- LAL LOW LEVEL ALARM
- DI CORIOLIS TYPE DENSITY INDICATOR
- DT DENSITY TRANSMITTER
- PHI pH INDICATOR
- FRIC FLOW RATIO INDICATOR CONTROLLER
- LG LEVEL GAUGE
- FIC FLOW INDICATOR CONTROLLER
- PIC PRESSURE INDICATOR CONTROLLER
- TIC TEMPERATURE INDICATOR CONTROLLER
- LIC LEVEL INDICATOR CONTROLLER
- LSH LEVEL SWITCH HIGH
- PCV PRESSURE CONTROL VALVE
- TCV TEMPERATURE CONTROL VALVE
- FCV FLOW CONTROL VALVE
- LCV LEVEL CONTROL VALVE
- II AMPERE INDICATOR
- PMI PARTICULATE MATTER INDICATOR
- WI WEIGHT INDICATOR
- ZS POSITION SWITCH
- XI MOTOR RUNNING INDICATION
- AP ANALYZING POINT

INTERLOCK DESCRIPTION

- I31, I34, I35:- LOW FLOW OF ACID WILL STOP AMMONIA FLOW
- I32, I36, I37:- LOW FLOW OF AMMONIA WILL STOP SULPHURIC ACID (SA) FLOW
- D-41:- ON STOPPAGE OF P-2:FCV-06 & FCV-10 i.e. AMMONIA & SULPHURIC ACID (SA) FLOW RESPECTIVELY TO D-1 WILL STOP.
- D-42:- ON STOPPAGE OF P-3:FCV-07 & FCV-11 i.e. AMMONIA & SULPHURIC ACID (SA) FLOW RESPECTIVELY TO D-4 WILL STOP.
- D-43:- ON STOPPAGE OF P-5:FCV-08 & FCV-12 i.e. AMMONIA & SULPHURIC ACID (SA) FLOW RESPECTIVELY TO D-6 WILL STOP.

LOGIC FOR FRIC-X10, X11 & X12

FLOW OF SA IS CONTROLLED BASED ON STOICHIOMETRIC RATIO (S.R) AS PER AMMONIA (NH₃) FLOW AND AS PER PH VALUE (PH) OF CIRCULATING SOLUTION. BELOW LOGIC IS TO BE USED FOR ACID FLOW RATE CONTROL:

CASE A: IF ACTUAL PH IS GREATER THAN SET VALUE OF PH, LOGIC TO CONTROL SA FLOW IS AS BELOW

$$SA = (\text{FLOW OF NH}_3 * S.R) + (C.V * \text{FLOW OF NH}_3 * S.R)$$

CASE B: IF ACTUAL PH IS LESS THAN SET VALUE OF PH, LOGIC TO CONTROL SA FLOW IS AS BELOW

$$SA = (\text{FLOW OF NH}_3 * S.R) - (C.V * \text{FLOW OF NH}_3 * S.R)$$

WHERE

S.R VALUE SHOULD BE IN THE RANGE OF 0.0 TO 5.0 WITH ONE DECIMAL

CORRECTION VALUE (C.V) FOR PH ADJUSTMENT SHOULD BE IN THE RANGE OF 0.0 TO 1.0 WITH ONE DECIMAL

DETAILS FOR LINE NUMBER DESCRIPTION: △

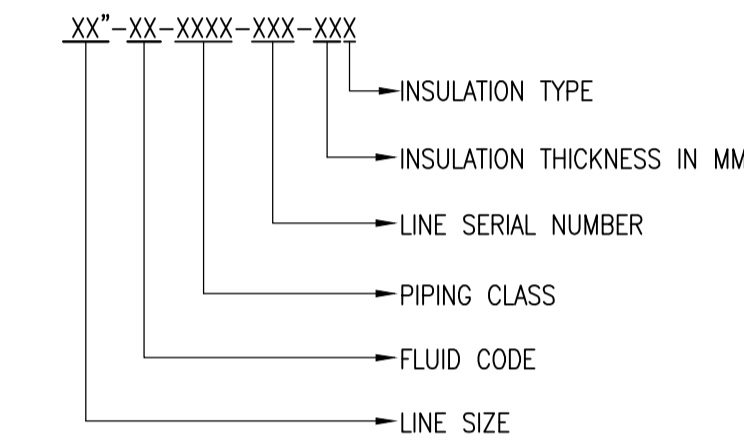

FLUID CODES: △

- AL - LIQUID AMMONIA
- AG - GASEOUS AMMONIA
- SA - SULPHURIC ACID
- RW - RAW WATER
- FW - FIRE WATER
- CWS - COOLING WATER SUPPLY
- CWR - COOLING WATER RETURN
- IA - INSTRUMENT AIR
- SM - MP STEAM
- SC - MP STEAM CONDENSATE
- PL - PROCESS LIQUID
- PC - PROCESS CONDENSATE
- PV - PROCESS VAPOURS
- ML - MOTHER LIQUOR
- AS - AMMONIUM SULPHATE
- EF - EFFLUENT

INSULATION TYPE: △

- H - HOT
- C - COLD
- P - PERSONNEL PROTECTION

ATTACHMENT-I

				GUJARAT STATE FERTILIZERS & CHEMICALS LTD.			
				P. O. FERTILIZERNAGAR DIST. VADODARA			
				P&I DIAGRAM FOR NEW 400 MTPD AMMONIUM SULPHAT PLANT AT BARODA UNIT			
		DGN	NRT/SSG	10/07/20			
		DRN	SDS/BMP	10/07/20			
		CHD	SRP	16/07/20			
		APD	VNP	16/07/20			
3	24/03/21	REVISED AS MARKED △	SRP	VNP	SCALE: - NTS		
2	26/02/21	REVISED AS MARKED △	SRP	VNP			
1	14/12/20	REVISED AS MARKED △	SRP	VNP	DESIGN DEPARTMENT		
0	16/07/20	ISSUED FOR EST./DET. ENGG.	SRP	VNP			
REV	DATE	DESCRIPTION	CHD	APD	JOB NO: -PROJ/228		
		9 6		A S IV		B S	
		0 0		0 1		0 1	
		PROJ		UNIT		FORM	
		CLASS		NUMBER		1 of 1	
		3		REV		3	

ATTACHMENT-II

GENERAL SPECIFICATION FOR WATER RING VACUUM PUMP

- 1.1. Vendor to furnish equipment arrangement drawing of pump.
- 1.2. The Pump shall be designed for the parameters defined in the Process data sheet.
- 1.3. All standard parts like bearings, oil seals, couplings for gear box / Pump and motor / gear-box etc. within a single service group are to be similar and interchangeable as far as possible.
- 1.4. All couplings / V – belts / Chain-sprockets shall be protected by suitably designed coupling guard.
- 1.5. Design of the machine shall be such that if partial dismantling at site is required, disturbance to connecting pipe – lines shall be of minor nature.
- 1.6. Direction of rotation of the pump shall be permanently marked & fitted at least on two easily visible sides.
- 1.7. Noise level, amplitude and frequency of vibrations of pump from no load to full load condition should be within acceptable limits during testing at supplier's shop as well as after permanent installation of the Pump on foundation at site.
- 1.8. Corrosion allowance for all carbon steel / cast iron parts should be minimum 3 MM while that for S. S, components should be minimum 1 MM.
- 1.9. Gear reduction unit or V-belt drive with accessories and auxiliary equipment necessary for its satisfactory operation shall be supplied. The gear reduction unit shall be selected as per AGMA Standard.
- 1.10. If the unit requires cooling water, the water inlet pressure and quantity per hour shall be specified.
- 1.11. In case of belt drive, the detail specifications of the belts and pulleys shall be furnished.
- 1.12. Normal speed should be adequately below the critical speed in order to avoid possibility of the vibration while stopping the pump. Supplier to ensure that margin of +/- 30% is available while selecting operating speed, i.e. 1st & 2nd critical speed should not be within 70% to 130% range of operating speed.
- 1.13. In case of use of roller bearings, the same shall be of SKF or equivalent reputed make having operating life of minimum 1,00,000 working hours (L-10 Life). Bearing shall be adequate to absorb axial thrust in either direction together with the thrust produced during full load condition and due to shaft expansion at operating temperatures. Bearing housing shall be dust proof, water proof and if necessary maybe water jacketed or bearings to be provided with heat dissipater. Bearing should run in no load to full load condition without any undue noise and over – heating. Grease nipple or oil plugs (like filling, overflow or draining) should be mounted on bearing housing at easily accessible point.
- 1.14. Any part of Copper and its alloys is not acceptable.

- 1.15. Name plate or specifications plate should be of stainless steel, permanently fitted on pump and should contain, item No., year of manufacturers, suppliers and purchaser's name, Material to be handled, input HP / KW, speed of Pump, total weight of equipment etc.
- 1.16. Proper lifting arrangement of adequate capacity shall be provided on the pump.
- 1.17. Vendor shall clearly indicate MOC of parts in their offer.
- 1.18. All internal tubing/ wiring shall be in vendor scope of work.
- 1.19. Special tools and tackles shall be listed, if any.
- 1.20. All the material to be used shall be free from any defects. Vendor shall supply necessary test certificates for review to GSFC.
- 1.21. Vendor shall submit the detailed offer with system Write-up, PID, Bill of material including MOC with necessary GA Drawing and Layout, etc. confirming the scope of work.
- 1.22. Suitable arrangement for maintenance space, walk way structure, ladder arrangement, inspection doors, and any other technological structure etc. to be provided.
- 1.23. Painting of complete equipment shall be as per GSFC Standard.
- 1.24. Anchor Bolts/Set Bolts, Nuts Washer/Gasket including all other installation accessories for the pump shall be in Vendor's scope of supply.
- 1.25. All drawings / documents along with operation and maintenance manuals as per requirement mentioned elsewhere in the tender document shall be submitted.
- 1.26. Noise level shall be within 85 dB at 1 m distance.
- 1.27. Activities not defined above, but required for successful operation and performance of the Pump, shall also be carried out by the vendor without any cost implication.

Table – I

**SCOPE OF WORK / SUPPLY OF BARE WATER RING VACUUM PUMP
(MECHANICAL ITEMS)**

The broad scope of work / supply for mechanical items for **water ring vacuum pump** shall include design, engineering, manufacture, inspection, testing, painting, packing and supply of material as mentioned in table below as a minimum. Supplier shall include in their scope of work/supply all other items essential for proper erection, smooth, trouble free and safe start-up, operation, shutdown as well as maintenance of the equipment / complete package.

(X): Required () : Not Required () N. A.: Not Applicable

(A) MECHANICAL ITEMS

Sr. No	Item Applicable for Each Machine	Required from Supplier	Remarks	Supplier's Conformation	R
1	WATER RING VACUUM PUMP AND RELATED ACCESSORIES.	(X)			
1.1	(X) Complete Pump	(X)	(X) Copper, Copper alloys shall not be employed, in any components of pump.		
1.2	(X) Water Lines with all necessary piping accessories such as valves, etc.	(X)			
1.3	(X) Complete baseplate / skid for pump package along with foundation bolts and lifting lugs, grout holes, vent holes etc.	(X)			
1.4	All necessary accessories such as: (X) Suction manifold (X) Discharge manifold (X) Water receiver tanks (X) Heat exchangers (X) Water circulation pumps	(X)			
2	Driver (Electric Motor)	(X)			
3	Transmission unit i.e. Coupling/ V-Belt drive	(X)	Min S.F shall be 1.5.		
3.1	V-belt/ Coupling guard	(X)			
4	Lubricants (X) Lubrication chart (X) First fill of lubricants	(X)	(X) For Plummer Block/ Bearings		
5	All necessary instrument items such as control panel, Junction boxes, Level gauges, transmitters etc.	(X)			
6	Spares	(X)	(X) 2 years recommended spares (X) Commissioning spares		

7	Submission of drawings and documents	(X)	(X) As per TABLE-2 attached along with this requisition.		
8	Shop inspection and testing	(X)	(X) As per Approved ITP/QAP		
9	Painting, preservation & Shipping preparation	(X)	(X) As per Specification attached along with this requirements.		
10	(X) Domestic Packing & forwarding	(X)			
11	Special tools	(X)	(X) As per Supplier's recommendations.		

Table – 2**SUPPLIERS DATA/ DOCUMENTATION REQUIREMENT FOR WATER RING VACUUM PUMP**

Submission requirement

(I): For information

(H): Hard copy

(R): For review

(S): Soft copy (Searchable pdf)

Sr. No.	DRAWINGS AND DATA REQUIRED	WITH BID	AFTER ORDER	SUBMISSION SCHEDULE	FINAL DATA
			R		
1	Complete water ring vacuum pump data sheet	S	S		1S + 4H
2	Foundation Outline Drawing	S	S		1S + 4H
3	General arrangement Drawing with Plan, Elevation and Cross section view of the pump	S	S		1S + 4H
4	Performance curve	S	S		1S + 4H
5	Allowable nozzle force And moments for piping	S	S		1S + 4H
6	Name plate details		S		1S + 4H
7	System write-up	S	S		1S + 4H
8	P&ID indicating scope of supply / work.	S	S		1S + 4H
9	Quality control plan/ Inspection Test Plan	S	S		1S + 4H
10	Inspection and test procedure for NDTs, Performance test procedure, Factory Run test procedure, Balancing procedure (if applicable), Packing and preservation procedure and all other tests procedures as per ITP/QAP.		S		
11	Manufacturer's Inspection and Test reports/ certificates as mentioned in ITP/QAP (including material test report etc.)		S		1S + 4H
12	Sub Supplier's list (For Mechanical, And Instrumentation items)		S		1S + 4H
13	Special tools list as per Supplier's Recommendation		S		1S + 4H
14	Installation, operation & Maintenance manual for Complete pump with All as built drawings, Auxiliaries, final		S		1S + 4H

	Datasheets and parts List.				
15	List of sub-vendors. Brochures and leaflets of all bought out items	S	S		1S + 4H
16	Utility consumption list		S		1S + 4H
17	Lubricant list for (With Lubricant chart and hydraulic fluid summary data sheet)		S		1S + 4H
18	Painting QC Record (Submit after final painting)		S		1S + 4H
19	Painting Procedure		S		
20	Inspection Record Dossier consisting all test records and certificates as mentioned in ITP/QAP.		S		1S + 4H

Notes:

- 1) Supplier to use and follow standard formats and common philosophy applicable for this project.
- 2) All documents shall be folded to size A4 while submitting.
- 3) Supplier to prepare and submit all documents / drawings complying common philosophy and formats.
- 4) Supplier to note that above list is indicative only. Any additional data/details required during detail engineering stage, it should be provided to Owner / Consultant without any implication.
- 5) All final As-built drawings, datasheets along with Inspection record dossier shall be supplied in 1 soft copy on CD/ Pen drive, along with 4 Nos. hard copies.

MECHANICAL DATASHEET

Name of equipment	Water Ring Vacuum pump	
Tag no.	XP-12 AB	
Qty	1 Working + 1 Standby	
Vendor	*	
Model No.	*	
Operating Conditions		
Fluid	Ammonia rich vapour + Air	
Condensables	Kg/hr	~22000
Non Condensables	Kg/Hr	~ 60
Operating Temperature	degC	Normal: ~ 60
Operating pressure	mmHG a	150 / *
System Volume	M3	450
Evacuation time	Min	100
Density @ operating temperature	Kg/m3	~0.131
Viscosity	cP	~0.011
Vapor pressure	Kg/cm2a	~0.32
Nature of fluid		Toxic, Corrosive
Performance data		
Maximum capacity at full open suction	M3/hr	*
Maximum vacuum at closed suction	Mm HG	*
Duty point capacity	M3/hr @ mmHG	*
Power Consumed	kW	*
Efficiency	%	*
Cooling Water Supply temperature	degC	*
Cooling water supply pressure	Kg/cm2g	*
Cooling Water return temperature	degC	*
Cooling Water flow rate	M3/hr	*
Pump speed	Rpm	*
Sealing water pressure	Kg/cm2g	*
Sealing water temperature	degC	*
Sealing water flow rate	M3/hr	*
Sealing water pressure drop	Kg/cm2g	*
Cooling water pressure drop	Kg/cm2g	*
Construction features		
Type		Water Ring
No. of stages		*
Impeller diameter	Mm	*
Impeller width	Mm	*
Bearing journal type		*
Bearing thrust type		*
Bearing impeller type		*
Lubrication		Oil / Grease / *
Lubrication grade		*
Suction flange size	in	*
Discharge flange size	in	*
Sealing type		Mechanical Seal
Make and model of seal		*

Material of Construction		
Casing		SS 304 L / *
Casing Wear ring		*
Casing Cover		SS 304 L / *
Impeller		SS 316 L / *
Shaft		*
Shaft Sleeve		*
Bearing Housing		SS 304 L / *
Casing bolting		*
Casing Gasket		*
Coupling		*
Coupling Make		*
Coupling model		*
Base-plate/ Skid		SS 304 L / *
Driver details		
Motor Make		*
Motor speed		*
Motor Rating	Kw	*
Weight details		
Weight of entire Skid	Kg	*
Weight of pump	Kg	*
Weight of motor	Kg	*
Weight of accessories	Kg	*
Overall dimension	Mm	L x B x H: *
Make List:		
Coupling		Rathi, Lovejoy, Unique, Fenner
Bearing		SKF, FAG
Plummer Block		SKF, MASTA,NTN
Motor		ABB, Siemens, CGL, BBL
Mechanical Seal		Flowserve, Eagle Burgmann, John Crane
V-Belts		SKF, Fenner, PIX

**QUALITY ASSURANCE PLAN
WATER RING VACUUM PUMPS**

Client	Manufacture's Name & Address	Pump Model		Client	Gujarat State Fertilizer and Chemicals Ltd.
		Quantity		Scheme No.	
		Tag No.		PO No.	
		QAP No.		Rev.	Page No.

SR. NO.	COMPONENTS & OPERATION	CHARACTERISTICS	CLASS	TYPE OF CHECK	QUANTUM OF CHECK	REFERENE DOCUMENT	ACCEPTANCE NORMS	FORMAT OF RECORD	AGENCY		REMARKS
									V	G	
1	2	3	4	5	6	7	8	9	10	11	
1	Raw Material Inspection										
1.1	Casing, Casing Cover, Impeller & Wear Ring, Bearing housing, cone	Chemical Properties	Critical	Chemical Analysis	1 Sample/ Heat/Batch	Approved Data Sheet / Approved CS Drawing	Material Test Certificate	P	R		
		Heat Treatment of Components	Critical	Heat Cycle	100%	Approved Data Sheet / Approved CS Drawing	Material Test Certificate	P	R		
		Mechanical Properties	Major	EL%, TS, YS & Hardness	1 Sample/ Heat/Batch	Approved Data Sheet / Approved CS Drawing	Material Test Certificate	P	R	Mechanical test shall be carried out after Heat Treatment, if any. Min. 50 BHN hardness will be maintained between casing wear ring & Impeller ring (integral with impeller) which shall be reflected in MTC.	
2.2	Shaft	Chemical Properties	Critical	Chemical Analysis	1 Sample/ Heat/Batch	Approved Data Sheet / Approved CS Drawing	Material Test Certificate	P	R		
		Mechanical Properties	Major	EL%, TS, YS & Hardness	1 Sample/ Heat/Batch	Approved Data Sheet / Approved CS Drawing	Material Test Certificate	P	R		
2.3	Bar Stock for Shaft	Ultrasonic Test	Major	Internal Defect	100%	Approved UT Procedure	UT Report	P	R	Applicable Dia. 50 MM and Above	
2.4	Casing, Casing Cover, Impeller, Shaft, Shaft Sleeve, Bearing housing, cone (AS & SS Material Only)	Positive Material Identification (PMI)	Critical	Chemical Element	100%	Approved PMI Procedure	PMI Report	P	W		
2.5	Fasteners (AS & SS Material Only)	Chemical Properties & Mechanical Properties	Major	Chemical and Mechanical Analysis	1 Sample Per Batch	Approved Data Sheet / Approved CS Drawing	Material Test Certificate	P	R		
2.6	Auxiliary Piping within pump skid	Chemical Properties & Mechanical Properties	Major	Chemical and Mechanical Analysis	Sampling Plan	Approved Data Sheet / Approved CS Drawing	Material Test Certificate	P	R		
2.6	Auxiliary equipments such as vessels, heat exchangers, Water circulation pumps etc.	Chemical Properties & Mechanical Properties	Major	Chemical and Mechanical Analysis	Sampling Plan	Approved Data Sheet / Approved CS Drawing	Material Test Certificate	P	R		
2.7	Base Frame	Chemical Properties & Mechanical Properties	Major	Chemical and Mechanical	Sampling Plan	Approved Data Sheet / Approved CS Drawing	Material Test Certificate	P	R		
2.8	Foundation Bolt	Mechanical Properties	Major	Chemical and Mechanical	Sampling Plan	Approved Data Sheet / Approved CS Drawing	Material Test Certificate	P	R		

3 In-Process Inspection										
3.1	Shaft	Total Indicated Run Out (TIR)	Major	TIR Measurement	100%	Manufacturing Drawing	TIR Report	P	R	
3.2	Impeller + Rotor	Dynamic Balancing	Major	Residual Unbalance	100%	ISO - 1940 Grade 2.5	Balancing Certificate	P	W	
3.3	Casing, Casing cover, Bearing housing, Impeller, Shaft & Wear Ring after Final Machining	DPT	Critical	Surface Defects	100%	Approved DPT Procedure	DP Test Report	P	R	
3.3	Auxiliaries such as Heat Exchangers, Storage tanks/ vessels/ circulation pumps	DPT	Critical	Surface Defects	100%	Approved DPT Procedure	DP Test Report	P	R	
3.4	Casing, All auxiliary equipments, circulating pumps, tanks, Heat exchangers, Piping etc.	Leakage test	Major	Leakage & Soundness of Casing Cover	100%	No Leakage and No Pressure Drop	Test report	P	W	
4 Bought Out Items										
4.1	Mechanical Seal	Air test	Major	API 682, 4th edition	100%	As per API 682 / Approved testing procedure	Test certificate	P	R	
		Hydro-test	Major	API 682, 4th edition	100%	As per API 682 / Approved testing procedure	Test certificate	P	R	
4.2	Coupling	Chemical and Mechanical Properties	Major	Chemical and Mechanical Analysis	100%	Manufacturing Specification	Manufacturer Test Certificate	P	R	
		Dynamic Balancing	Major	Residual Unbalance	100%	ISO - 1940 Grade 6.3	Manufacturer Test Certificate	P	R	
5 Assembly and Testing										
5.1	Performance Test with Shop Motor + Mechanical Run Test (MRT) for 4 Hours	Vacuum Generated	Critical	Performance Test	100%	Approved Data Sheet / BS 1571/ Approved Testing Procedure	Test Report and Tested Curve	P	W	
		Flow capacity								
		Free air delivery								
		Brake kW								
		Speed, Vibration, Noise Level, Bearing temp. Measurement, Seal Leakage								
5.2	Assembled Complete Pump Package	Overall Dimensional Check	Major	Overall Dimensions	100%	Approved GA Drawing	Dimension Report	P	W	Witness 100 % Quantity
5.3	Strip Test	Check for Wear / Scoring & Rubbing Marks on Wear Ring Surfaces	Major	Visual	100%	Check for Wear / Scoring & Rubbing Marks on Wear Ring Surfaces	Strip test Report	P	W	Strip test is applicable in any case. (i.e In case no abnormal sound coming from pump during performance test then also strip test shall be carried out.
6 Final Inspection										
6.1	Assembled Pump Set	Painting	Major	Visual, DFT & Shade	100%	Approved Painting Procedure	Painting Certificate	P	W	Passivated Components will not be Painted
6.2	Assembled Pump with all accessories	Completeness and Quantity Verification and Visual	-	-	100%	BOM / PO	Compliance Report	P	W	

6.3	Spares	Visual and Quantity Verification	Major	Visual	100%	BOM / PO	Fitment and Interchangeability Certificate	P	W	
6.4	Assembled Pump with all accessories	Packing	Major	Visual, Box Identification	100%	Packing Procedure	Packing Note	P	W	
6.5	Dispatch Clearance	Documentation from 1.1 to 6.5	Critical	-	-	-	Dispatch Clearance		H	

Legends:										
V - Vendor			P- Perform			R- Review				
G- GSFC			W- Witness			H- Hold				

Notes:

ATTACHMENT- III

GENERAL SPECIFICATION FOR ELECTRICAL REQUIREMENTS

SCOPE OF WORK:-

Following is the scope of work for electrical:

Supply, installation, testing and commissioning of all electrical items of new dock leveller package unit from downstream of 415 V power source given by GSFC:

- a. Electric motors
 - b. VFD panel
 - c. Electrical panel
 - d. Local push button control stations.
-
- 1.0 GSFC will provide single point 415V, 3 phase and neutral, 50 Hz AC power supply to the vendor's panel. Further distribution of power from vendor's electrical panel to all machines shall be in vendor scope.
 - 2.0 New Panel shall be single front, draw out / non draw out type, floor mounted, fully compartmentalised for incoming feeder, outgoing feeders, bus bars chamber and cable termination chamber, IP 54 protected, Busbar supports shall be made of fibre glass reinforced polyester (FRP) SMC insulators. Incomer feeder shall be provided with Switch fuse unit (upto 400A)/ACB, digital multifunction meter and R, Y, B indicating lamps, CTs, stud type terminals, push button with cord, ammeters etc. All outgoing DOL feeders up to 55 KW shall have switch fuse unit, contactor, bimetal overload relay, individual centre tap earthed control transformers, ON/OFF/TRIP indicating lamps, CTs, stud type terminals, reset push button with cord etc. All outgoing switch fuse unit feeders shall have switch fuse unit and ON/OFF indicating lamps. MCC shall have 10% spare feeders with minimum one spare feeder of each rating. Cable entry shall be from bottom and undrilled cables gland plate of 3 MM thickness shall be provided. Earth busbar chamber with copper earth bus bar shall be provided. Earth bus shall be extended at the both end of panel for termination of earthing cable for panel earthing. Busbar shrouds shall be provided to cover main busbar, bolted joints of busbars and all live parts. Hylam partition plates between disconnect contacts shall be provided. Additional ISMC frame of 75 MM along with the 50 MM integral base frame shall be provided.
 - 3.0 New VFD panel shall be single front, non draw out type, floor mounted, IP 54 protected, Incomer feeder shall be provided with Switch fuse unit, R, Y, B indicating lamps, CTs, stud type terminals, push button with cord, ammeters etc. All outgoing DOL feeders shall have individual centre tap earthed control transformers, ON/OFF/TRIP/FORWARD/REVERS indicating lamps, CTs, stud type terminals, reset push button with cord, speed increase-decrease push buttons, reverse-forward

push buttons, local-remote, auto-manual selector switch, cooling fan and filters etc. Cable entry shall be from bottom and undrilled cables gland plate of 3 MM thickness shall be provided. Earth busbar chamber with copper earth bus bar shall be provided. Earth bus shall be extended at the both end of panel for termination of earthing cable for panel earthing. Hylam partition plates between disconnect contacts shall be provided.

3.1 Control transformer and CT shall be designed as per required cable length. Cable length shall be furnished by GSFC during detail engineering stage.

3.2 For control and logic circuits auxiliary contactors shall be use. No auxiliary relays shall be used for control and logic circuit.

3.3 Power contactor shall have 4 NO + 4 NC auxiliary contacts.

3.4 For incoming / outgoing cables feeders bolted stud type power terminal block suitable for connecting crimping type copper lugs shall be provided in electrical panel to terminate incoming/outgoing cables in separate alley/ compartment. All internal wiring shall be carried out up to terminal block. Cable entry shall be from bottom only.

3.5 SFU shall be selected 1.3 to 1.5 times the required load.

3.6 CT secondary shall be of 1 A. Minimum wire size for CT wiring shall be 2.5 sq. mm. Copper cable.

3.7 VFD shall be suitable for 46 Degree centigrade of ambient temperature.

3.8 Door mounted variable frequency drive operation unit with digital display & consisting of start/stop, indication and speed control soft buttons shall be provided.

3.9 Door mounted stay put type, turn to release push button for EMERGENCY stop of VFD unit shall be provided.

3.10 Speed variation push button shall be provided on the VFD panel.

3.11 VFD shall be provided with input and output chocks

3.12 VFD panel shall be provided with the cooling fans with door mounted air filters.

3.13 VFD panel shall be suitable for speed variation from local and VFD panel.

3.14 VFD shall have a voltage dip ride through feature.

3.15 Cable schedule for VFD panel outgoing and incoming cable shall be provided by the vendor.

- 3.16 VFD panel shall be supplied and commissioned by package vendor.
- 3.17 VFD panels shall be provided with sufficient nos. of signal splitters / signal multiplier and isolators for the various indications i.e. Ampere, speed in local, VFD panel, DCS etc. and speed variations as required by the process.
- 3.18 Inspection & testing shall be carried out at manufacturer's works as per relevant IS. In general, Following tests shall be carried out on electrical panel:
- a. Dimensional checks.
 - b. Wiring checks and electrical continuity checks.
 - c. Functional tests
 - d. HV test
 - e. Insulation resistance test.
- 3.19 All required nickel plated brass double compression type cable glands shall be supplied by vendor.
- 3.20 All cables termination and supervision shall be in the vendor scope.

- 4.0 Motors- 3 Phase, 415V, 50 Hz, TEFC, IP-55 protected, epoxy painted, full voltage starting, continuously rated, suitable to operate at 46 Deg.C ambient temperature, Class-F insulated but temperature rise limited to class B insulation, ENERGY EFFICIENT (IE2), Industrial type squirrel cage induction motor suitable for outdoor installation in safe areas, conforming to IS- 325, fully complying to following notes. The motors shall have stainless steel name plates and standard bare shaft extension with key.
- 4.1 Motor shall be Class-F insulated, but temperature rise restricted to Class-B insulation.
- 4.2 Motor shall be suitable for VFD application.
- 4.3 Motor above 55 KW shall be provided with space heater to keep motor temperature at least 5⁰C above the outside ambient temperature, during idle condition.
- 4.4 Motor shall be capable of starting and acceleration to its rated speed at 75 % of rated voltage. Motor shall also be suitable for restarting a residual voltage of 40 % in phase opposition to the supply voltage.
- 4.5 Terminal box, terminal cap and cable entry plate shall be made from Cast Iron of suitable grade as per IS-210. Insulators shall be made of porcelain/ polyester/FRP. Terminal bolts and terminal links shall be made of electrolytic copper suitable for required current carrying capacity and suitable to terminate required size of crimping/soldering type copper lugs.

- 4.6 The terminal box for motor shall be sized to withstand corresponding fault current for 0.25 secs. The terminal box of motor shall be amply sized for cable termination and shall have six terminals with terminal shorting strips, cable lugs and double compression nickel plated brass cable glands for cable termination. Separate terminal box shall be provided for space heater terminals and power terminals. Terminal markings shall be as per BIS. Terminal box shall be orientable in four positions of 90⁰. Separate terminal box on motor shall be provided for following :
- Main power cable.
 - Space heater cable.
- 4.7 The motor shall be suitable for the driven machine specified. Motor shall be suitable for starting and reaccelerating the specified load. Starting and reacceleration shall be successful even with a voltage drop of about 25% at motor terminals.
- 4.8 Locked rotor withstand time for hot condition at 110 % of rated voltage shall be more than acceleration time of motor with full load connected , at 75 % of rated voltage by 5 secs for motor having acceleration time more than 20 secs and by 2.5 secs for motor having acceleration time less than 20 secs.
- 4.9 All motors shall be suitable for direct-on-line full voltage starting.
- 4.10 The motor shall be suitable for bi-directional rotation. The cooling fans shall be of non corrosive metal.(Cast iron or cast aluminium) Plastic fans are not acceptable.
- 4.11 Motor shall be manually controlled by a local control station close to the motor and from LV Switchgear or MCC or DCS , as per the process requirements.
- 4.12 Motors shall be provided with two nos. of earthing terminal for earthing of the motors.
- 4.13 Motor shall be sized on following basis and final nameplate rating of motor shall be rounded up to immediate higher standard rating :

BHP required at Driven machine shaft	Motor nameplate rating
18.5 KW and less	125% of actual max. BHP required by driven machine
Above 18.5 KW to 75 KW	115% of actual max. BHP required by driven machine
Above 75 KW	110% of actual max. BHP required by driven machine

- 4.14 Motor shall be designed for following starting duty

- Equally spread starts per hour from cold condition: 4
- Successive starts form cold conditions- : 3
- Successive starts form hot conditions- : 2

4.15 Following Documents shall be submitted for each motor:-

- i. Certified dimensional drawing
- ii. Torque speed curves with GD2
- iii. Thermal withstand curves (Hot & cold) with heating & cooling time constant.
- iv. Routine test certificate
- v. Type test certificate
- vi. Following Performance curves
 - Starting current vs time for 80 %, 100% & 110 % Vr.
 - Efficiency Vs output
 - Power factor Vs output.
 - Negative phase sequence withstand current Vs time curves for motor above 110 KW.
- vii. Detailed drawing of terminal box and space heater.
- viii. Motor design data sheet.
- ix. Test certificate to prove degree of protection for enclosure for the both digits.
- x. Test certificate to prove SC withstand capacity for motor and terminal box.

4.16 Motor shall be tested in accordance with relevant Indian Standard at Manufacturer's works.

5.0 Local control station shall be fabricated from LM6/FRP material and with canopy. ON push button shall be shrouded and OFF push button shall be stay put type with padlocking facility and epoxy painted with paint shade 631 as per IS 5.

6.0 Preferred Make of electrical items shall be as under:

- a. Motors- Bharat Bijlee/Crompton/Siemens/ABB/NGEF.
- b. Cables & wires- Torrent/ Polycab/ KEI/ Unistar/ FGI/ CCI/ Finolex
- c. MCC / Power distribution board- Indian switchgear/ Elecmech/ Siemens/ L&T/Bharat Engineers.
- d. Push button station- Hansu/ Pushtron/ Flexpro/ Dynamic control.
- e. Multifunction meters- Conzerve (Schneider)
- f. CT/PT/Control transformer- AE/ Precise/ Indcoil/ Siemens.
- g. Panel components- L & T / Siemens
- h. Terminals- Elmex.
- i. Cable gland – power engineering/comet/CHI.

j. Cable lugs - Dowell

7.0 Vendor shall furnish following documents along with their offer:

- a. Electrical load list
- b. Detailed Single line diagram of entire electrical system.
- c. Tentative GA drawing of MCC/ power distribution Board.

8.0 Vendor shall furnish following documents for approval of GSFC during detailed engineering:

- a. Detailed Single line diagram of entire electrical package system
- b. Enquiry and order specification for all electrical items
- c. Vendor drawings for all electrical items.
- d. Test certificates of electrical equipments.
- e. GA drawing of MCC/ power distribution Board.
- f. Electrical load list
- g. Control schematic diagrams of all feeders showing metering, protection, annunciation etc.
- h. Wiring diagram with terminal block disposition, ferrules number etc.

ATTACHMENT-IV

General Specification for Instrumentation Requirements

Note: We have prepared this requirement as general for package unit. Hence, Vendor shall consider only applicable point and mention "NA" where ever it is not applicable for your supplied package system.

(A) MAIN CONTROL PANEL :

1. The Control panel shall be of "Rittal" make. It shall be suitable for outdoor field installation complying of given hazardous area classification.

Vendor shall clarify for Instrument control panel's door opening (i.e. from front side only or from front and rear both). Vendor shall provide Control panel General Arrangement drawing/photographs of the same for more clarity. Vendor shall ensure that Control Panel's Cable entry shall be from bottom of the panel.

Vendor shall provide the Instrument control panels size and it's General Arrangement drawing along with opening (i.e. Door) details. Also, panel Installation guide of all panels shall be submitted. Panel sketch indicating panel size with door opening clearance and required clearance from all the side of panel is to be submitted.

Vendor to provide the panel base frame drawing in advance so that our civil dept can make the panel frame ready.

2. The Instrument control panel shall be physically separate from electrical panel.i.e. Power cabinet is to be separated from Control cabinet. All signal exchange between electrical & instrument panels shall be clearly identified and terminated separately & properly. For contacts/commands going to electrical motors and electrical equipment shall be provided through relays.

3. GSFC will provide 110 V AC +/- 10%, 50 Hz, 1Ph UPS power supply **for control cabinet** at single point. Further, power distribution shall be carried out by vendor. However, all Lighting / Fans / Air conditioners / cooler Utility points shall be catered from 230 VAC power source separate from control power. Vendor to indicate Power requirement for Instrument control panel if any.
- The power distribution inside panel for various instruments & controls shall be through MCBs as required for 110V AC and 24V DC both.

4. For 24 V DC Power supply distribution inside panel for other components i.e. for loop power to field transmitters etc, vendor to provide Siemens make power supply of 110V AC to 24V DC of suitable rating inside panel.

5. Panel Indicator and associated control components like relays & contactors etc. shall be suitable for outdoor panel installation. Necessary air circulation / cooling arrangement shall be done with vortex cooler in control panel if panel is installed in field/outdoor area for reliable functioning of control components.

- For Indoor panel installation, vendor to inform the requirement of Air Conditioning with capacity.
- For the inst. control panel to be installed in field area, necessary protection shall be provided against water ingress, dirt and sun light.

6. All front panel mounted instruments like controllers, indicators shall be operated on 110V AC power supply and suitable for outdoor installation of safe area classification. Tripping contact for motor tripping etc. are to be generated from P&F make barrier only and **not** from indicator/controller.

- Indicator/controller on board NO/NC contact can be used **for alarm only**.

7. As per requirement of Process dept., Following Analog signals shall be repeated with P & F make repeater barrier in your Local panel for retransmission of signal to CAPRO-I control room-HX section as shown in our P&ID no. 03-CP-CS-00738, Sheet 1 of 1, Rev.0:

- i. Pressure transmitter : Storage Tank pressure
- ii. Level transmitter : Storage Tank Level
- iii. Flow transmitter : CO2 flow to plant
- iv. Temperature transmitter : CO2 temperature

8. P & F make active and passive barriers shall be used in panel for isolation and intrinsic safe application. For RTD input, 4 to 20 mA input etc through P& F make converters only.

- Vendor shall consider Barrier / Isolators for all type of signals.

9. Repeated contacts shall be provided for each and every alarm and trip contacts generated in panel for existing Capro-I plant panel indication in plant control room, if required. Necessary hardware/arrangement shall be considered inside the control panel by vendor.

10. All alarms and trip indications on front panel / HMI shall be audio-visual type.

11. All wires to & from panel components inside the panel shall be properly placed in wire ways (PVC). Suitable space (Minimum 100 mm) shall be kept between wire way & terminal strips.

12. For wiring inside the panel both Source & Destination terminal reference (Self+Cross type) shall be maintained for ferruling for identification of wires. The ferrules used shall be heat shrinkable and continuous white color strip with machine printed identification tag in black color as per example at "Annexure-(A)". Each component inside the control cabinet shall be labelled with proper identification tag.

- All Terminal block inside panel/Junction Box shall be of knife-edge (push-pull) type.

13. If panel is to be installed in open field area in shed, necessary panel roof/cover shall be provided for protection against water ingress, dirt and sun light and proper cooling system for panel shall be provided.

14. If the control panel is close cubicle type, sufficient working space shall be provided inside control cabinet with one door on either side / back side of panel as suit to site.

15. New control Panel shall be pre-wired for all the AI/AO/DI/DO and with necessary hardware to communicate (Retransmission of signals) with existing capro-I plant panel indication, as required by our process dept.

16. Panel enclosure shall be of IP-54 and having LED indication for trip and alarms.
17. As required, All I/O communication between new panel supplied by vendor and existing capro-I plant panel indicator shall be through hardwire and not through soft (i.e. not through serial communication module).
18. All programmable devices must be supplied with full licensed software and connecting tools, converters and cables etc.
19. Redundant power supply shall be with redundant Diode O'ring and with proper isolation. (i.e. with suitable size of MCB, fuse for isolation) at each points.
- Power distribution for various instruments & controls shall be through MCBs & fuses as required for 110V AC and 24V DC both.
20. Complete implementation of system / logic shall be in vendor scope with all requirements which are raised during detailed engineering or ask by our process dept.
21. For third party communication if any Vendor's supervision is required.

(B) Mandatory Instrumentation Spares :

1. Vendor shall consider 20% or minimum ONE whichever is higher against each type of installed spare for field instruments as well as panel instrument spares.
2. Vendor to supply one to one spare for each instruments under their scope of supply considering instrument spare.
3. Vendor shall submit the properly tabulated "Instrumentation Spares List" which includes Field side as well as panel side instruments and shall require approval by GSFC.

(C) FIELD INSTRUMENTATION:

1. The supplier shall clearly indicate the location of instruments in their P & I Diagram with all LEGENDS as per standard engineering practice.
2. Pressure gauges shall be provided with isolation and drain facility i.e. with 2way manifold.
3. For pressure measurement, 2 wire Pressure transmitter with manifold shall be provided instead of pressure switch.
4. For flow measurement, Orifice Assembly with DP transmitter with manifold shall be provided.
5. All process transmitters shall be 2 wire type, SMART having HART compatibility and working on 24 V DC supply. Necessary 24 V DC supply and power distribution arrangement shall be provided by package vendor in their panel.

6. Single piece bar stroke Thermowell (1.5" flanged with rated pressure rating as required) with RTD (Pt-100 Duplex element as per DIN 43760) type temp sensor shall be used for all temp. measuring / control requirements. Filled system / thermostat shall be strictly avoided. Spring Bayonet type element shall be strictly avoided. No element shall be in direct contact with process and shall be through Thermowell only.

7. Transmitter shall be supplied with Manifold and all accessories.

8. All field mounted instrumentation and Junction box shall be weather proof to IP-65.

9. From package unit field instrument to new control panel, Vendor shall supply signal and control cables shall be PVC coated, armoured, 1.1 KV grade having multi strand copper conductor. Control cable wiring for contacts shall be 1.5 sq.mm size and signal cable wiring shall be 0.75 sq.mm size. Further, All signal shall be retransmit to Capro-I control room panel through multicore cable.

11. Vendor shall supply suitable size of SS-304/316 (Stainless Steel) double compression type cable glands for all field instruments, Junction box and panel for cable entry with separate gland plate for anti-Rodent. Required all accessories shall be supplied by vendor. All cable shall be with proper Lugs only.

12. Maximum available instrument air pressure is 3.5 kg/cm²g in plant hence all pneumatic actuators shall be suitable to operate on this pressure.

13. Direct termination of Instruments is not allowed, Please consider Ex-proof Junction Box for all instruments. Vendor shall lay individual field instrument signal/power cable through dedicated AI/AO/DI/DO/Power supply Junction box / supplied panel. Further GSFC shall lay only multi-core cables from vendor's new panel upto existing capro-I plant panel in control room.

(D) INSTRUMENT / COMPONENT MAKES (GSFC- APPROVED VENDOR LIST):

NOTE: Following are the GSFC-standard approved vendor list for different Instrumentation Items. If any instrument are not covered in the list, then vendor has to first take the approval of GSFC before proceeding.

- Control Panel – Rittal.
- At least 3 sets of hard copy and 1 set of soft copy with one no. of as-build programmed memory unit shall be provided.
- RTD to Current Convertors - P & F make Model: KFD2-GUT-EX1.D
- 24 V DC power supply– SIEMENS Only.
- Terminals – WEGO / Elmax or equivalent
- Relay Cards - P & F / Phoenix
- Safety Barriers or Trip Amplifier or Similar Modules – P & F
- Relays – Omron
- Cables – Associated cables / Associatedflexibles& wires/ Udeypyrocables
- Cable glands / conduits – Ex-protecta / Finolex
- Contactors – Siemens / ABB
- MCCB / MCB – Siemens / MDS / Havells /Schneider

- Panel Instruments like Temp. Controller, Recorders or Single Loop Controllers – Yokogawa only.
- Orifice Flange assembly with plate – Fairflow& Control / General Instruments / Micro – Precision / Aditya Engineering Works.
- DP/P transmitter – Emerson / Yokogawa
- I/P Converter – Yokogawa / Emerson / Schneider (ABB)
- Control Valves (Globe type) – Emerson Process Managements Chennai / IL / KSB-MIL / Dresser Valves / Samson.
- Control valves (Rotary Plug type) – Emerson Process Managements Chennai / Samson.
- Control valves (Butterfly type) – Metso India / Pentair – TYCO valves / IL / Emerson Process Managements Chennai.
- Self-Regulating Valves – Fisher / Samson / Nirmal
- Solenoid Valves – ASCO only
- Manifold/Tube Fittings – Excel Hydro / True Way Corporation / Excelsior Engg. Works / Aditya Engineering Works.
- SS Tubes – Ratnamani metals / Heavy Metals / National Metals / Ratandeeep
- Mass flow meter – Emerson / E & H
- Magnetic Flow meter – Krohne Marshall / Emerson / Yokogawa
- Capillary Type Level Transmitter or Pad type LT – Emerson / Yokogawa
- Displacer Type Level Transmitters – Schneider / Magnetrol / Emerson Process Managements Chennai.
- Level Transmitter (Radioactive Type) – Emerson / E & H
- Level Switch – Magnetrol / Chemtrols
- Temperature Transmitter – Emerson / Yokogawa
- Temperature Gauge with Thermowell – Waaree – Baumer / Thermal Instrument / Wika Instruments / Detriv Instrumentation / ALTOP.
- RTD (Duplex only) with Thermowell – Detriv Instrumentation / ALTOP / Thermal Instrument /Wika Instruments.
- Pressure switch – Switzer / Aschcroft
- Pressure Gauge – Waaree – Baumer / Mass / General instrument / Wika Instruments
- Field Junction Box – Baliga / Ex-Protecta / Metro/ FCG Flame Proof Control Gears
- Air Filter Regulator – ShavoNorgren / Placka
- Signal or Power cables – Associated Cables / Udey Pyro cables / KEI Industries / RR Kable /GEMSCAB Industries / T.C. Communication / CMI Energy.

(E) GENERAL NOTES ON INSTRUMENTATION:

1. Competent Instrumentation Engineer shall be exclusively allotted for this project by package vendor. Vendor shall visit the GSFC, Vadodara site for detail engineering before submitting and finalizing the technical offer.
2. Normally SS 316 tubing of ½" and ¼" OD sizes only are to be used based on the application for all requirements. SS braided hose pipe connection shall be avoided wherever possible.
3. Engineering shall be done as per following codes & standards,
 - Instrument Society Of America (ISA)
 - American Petroleum Industries (API)
 - National and local regulation and laws.

4. Instrument isolation valves shall be 1/2" SS-304/ SS-316 Globe/Ball type valve only as per applications.

5. Package unit supplier shall submit specifications of all instrument & control systems to GSFC after placement of Purchase Order for main equipment for comments and approval. UN-priced PO copies shall also be forwarded to GSFC for reference.

6. Vendor shall consider minimum 20% spares and 1 no against installed 1 no spare for field instrumentation as well as panel.

7. For Complete Instrumentation system, whatsoever items/ services/ co-ordination are required for successful Erection & Commissioning, start up of this package shall be in vendor scope. All instruments are installed and wired to terminal boxes in junction box/panel. i.e. Complete package unit shall be supplied in pre-assembled condition.

- ❖ As required, Vendor shall make the provision for retransmission of signals in supplied panel.
- ❖ M/s. GSFC will do the erection of the instrumentation items under the supervision of Vendor's site engineer and as per the documents/drawing provided. Further, Vendor shall specifically elaborate any other Instrumentation item requirements which are supposed to be procured/supply by M/s. GSFC.

8. Supervision for Installation and Commissioning of Complete Package Unit shall be in vendor Scope of Work. Competent Instrumentation Engineer shall be exclusively allotted for this project by package vendor for supervision.

9. Complete interlock testing shall be in Vendor scope. Vendor shall test the final interlock checking at GSFC site.

10. Vendor to ensure that supplied panel related components shall not be obsolete in near future.

11. Vendor shall give the warrantee of complete instrumentation system as per terms finalised for complete package unit.

(F) DOCUMENTATION :

1. Vendor to provide P&ID, Instrument Index, "I/O list" to check / finalise the I/Os, "Bill Of Material" with all Field side and panel instrument related components Type, Make, Model/Part no. and otherall required details, "Specification final datasheet", calibration report, certifications and all other documents/ Catalogue for each instrument item under this package unit and same shall be provided in ENGLISH language without fail for information and approval for our review / comments (if any) for necessary incorporation by vendor.

2. Vendor shall provide instruction and troubleshooting manual for each and every field instrument as well as General Arrangement drawing, Hook up drawing, Panel & JB complete wiring drawing, JB schedule, Cable schedule, Cause and consequences diagram, HMI (operator panel) graphics function & operation manual, logic and interlock drawing with terminal and ferrule details for given panel as-built drawings.

3. Interlock cable schedule between power and control cabinet shall be submitted.

Note: Above mentioned documents list are tentative. Vendor shall provide all there standard list of documents which required for commissioning as well as for future maintenance.

Annexure-(A)

Example of Self + Cross Ferruling :

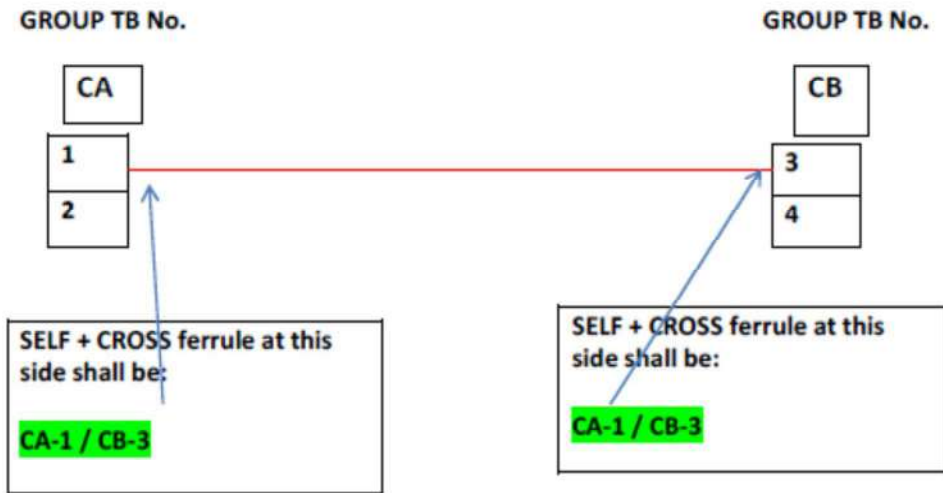

i.e. For nearest Terminal Block no. of cable 1st (SELF address) and then "/" 2nd (CROSS address) in which Terminal Block no. cable is terminated.

STANDARD SPECIFICATIONS FOR FABRICATED EQUIPMENT (WITH SUPPLIER'S DESIGN)

1.0 GENERAL —

- 1.1 This specification covers the requirements of design, materials, fabrication, inspection, testing and documentation of fabricated equipment.
- 1.2 In case of any conflict between this specification and drawing/data sheet, details shown on the drawing/data sheet shall be treated as FINAL.

2.0 SCOPE

2.1 The equipment are to be designed by the Supplier. Supplier shall be fully responsible for the design, fabrication, quality of materials, quality of workmanship, inspection, testing and fully comply with the requirements of ASME Sect. VIII, Div.1/2, ASME Sect. IX, TEMA and Owner's requirement, wherever specifically mentioned.

2.2 Supplier shall carry out detail design calculations and prepare fabrication drawings with detail of Bill of Material, based on the requirements of applicable Codes/Standard, material specification, design condition and dimensions mentioned in the data/specification sheet. Design calculations shall be submitted in Triplicate for approval of owner and / or authorized agency.

Supplier shall enter into the contract with Authorized Agency for drawing approval and inspection services. Supplier shall submit four prints of every revision of drawings for Owner's perusal and comments. This shall be done simultaneously with submission of drawing to Authorized Agency for their approval. Owner will furnish their comments at the earliest on receipt of drawings. In case comments given by Owner conflict with those given by Authorized Agency, the same will be pointed out by supplier and decided after discussion with Owner. All other comments given by Owner will be incorporated.

2.3 Supplier shall not deviate from the requirements with regard to materials, dimensions and other details given in the data/specification sheet unless specifically agreed by the Owner.

1	25-11-99	Reviewed & Updated	<i>[Signature]</i>	<i>[Signature]</i>
0	22-12-95	Reviewed & Updated	<i>[Signature]</i>	<i>[Signature]</i>
REV.	DATE	DESCRIPTION	CHECKED	APPROVED



GUJARAT STATE FERTILIZERS & CHEMICALS LTD.
(DESIGN DEPARTMENT)

PROJECT	UNIT	FORM	NUMBER	SHEET	REV.
-	-	L 5	000060	1 OF 7	1

- 2.4 Approval of the Supplier's drawing, acceptance of the equipment by Owner's inspector or Authorized Agency, does not relieve the Supplier's responsibility in fulfilling the requirements of applicable code, data sheet and this specification.
- 2.5 The internals such as trays, filter element, distributor, etc. are included in the scope of supply unless otherwise stated in the data/specification sheet. Supplier shall forward detail specifications/drawings of such internals for Owner's reference/review.
- 2.6 The supplier shall furnish size, quantity and material of foundation / holding down bolts based on forces and moments due to wind load and seismic loads as applicable as per relevant Indian Standards, in empty, operation and Hydro-test condition.
- 2.7 Nozzle orientation, support details, cleats for platform/ladder/insulation and details of mounting flange for agitator, pump etc., wherever applicable, shall be finalized and conveyed to the supplier during the course of fabrication.
- 2.8 Supplier shall furnish a bar chart, showing their schedule of order execution for Owner's information/review, within 10 days of placement of order.

3.0 DESIGN

- 3.1 Design shall be carried out as per the requirements of latest edition of applicable code.
- 3.2 Requirement of reinforcing pads shall be calculated as per design code. However, for nozzle size of 3" NB & above, reinforcing pads shall be provided equivalent to thickness of component to which nozzle is attached and having width of 50 mm.
- 3.3 Design should take care of external loading such as wind, earthquake, vibrations in agitated vessels and aspects such as flow induced vibrations, static deflection and vibrations due to wind etc.
- 3.4 The applicable local standards for external loading to be considered are latest edition of -
 - IS:875 - Code of Practice for Structural safety of Buildings Loading standards
 - IS:1893 - Criteria for earthquake resistant design of Structure
- 3.5 Wherever service conditions call for application of statutory codes such as IBR, CIE, etc. Supplier shall provide all necessary documents required for approval.
- 3.6 Wherever expansion joint is required it shall be as per TEMA/ASMA & GSFC specification.

4.0 MATERIALS

	GUJARAT STATE FERTILIZERS & CHEMICALS LTD. (DESIGN DEPARTMENT)					
			PROJECT	UNIT	FORM	NO. DRAWING
		L 5	000060	2 OF 7	1	

- 4.1 All the materials required for completion of the equipment shall be arranged by the Supplier.
- 4.2 Materials shall strictly conform to the specifications mentioned on the data sheet. Supplier shall submit test certificates showing chemical & physical properties, heat mark etc. If test certificates are not available, Supplier shall carry out chemical as well as physical tests to Authorized Agency/Owner's satisfaction.
- 4.3 All flanges shall be forged flanges as per ANSI B16.5 unless otherwise specified. Flanges up to & including 3" NB shall be Weld Neck Type and above shall be slip-on type, conforming to SA 105 for CS and applicable grade of SA 182 for low alloy and stainless steel. For SS equipment, flanges of 4" NB & above shall be made by weld deposition of suitable grade of SS on CS/low alloy steel plate/forged flanges.
- 4.4 Bolting material shall conform to suitable grade of SA 193/SA194.
- 4.5 Gasket material shall be specified in data sheet and shall satisfy Code/Standard requirements.
- 4.6 Structural steel shall conform to IS:2062 or its equivalent.
- 4.7 The following material shall be supplied in excess to the actual requirement as mentioned below :

- i) Studs, Bolts, Nuts - 10% (Min.4 Nos.)for each size
- ii) Gaskets - 3 Sets for each Joint

4.8 THE NAME PLATE SHALL BE AS PER OWNER'S STANDARD DRAWING ENCLOSED HEREWITH.

5.0 FABRICATION

- 5.1 Fabrication shall not be commenced unless Supplier's drawings have been approved for fabrication by Owner/Authorized Agency.
- 5.2 Plates/pipe edge preparation for welding for carbon steel parts shall be by machining, grinding or by flange cutting followed by grinding. Stainless steel plates/pipes, etc. will be cut by shearing or plasma cutting followed by grinding.
- 5.3 All welding shall be in accordance with latest edition of applicable code. Welding of all pressure parts shall be double butt welded with complete fusion and full penetration. Second side welding shall be carried out after back chipping or grinding of root pass to parent metal and DP testing. Root run of weld which are not accessible from second side shall be done by argon arc welding. Supplier shall get the approval of Authorized Agency for the electrodes they propose to use for welding.
- 5.4 All sharp corners shall be suitably rounded off and ground smooth.
- 5.5 Welding procedure shall be as per latest edition of applicable code and shall be submitted for approval of Authorized Agency/Owner. Only qualified welders shall be employed.
- 5.6 Dished ends shall be made of single piece construction. In case of dished ends fabricated in segments, the weld shall be fully radiographed after forming.



GUJARAT STATE FERTILIZERS & CHEMICALS LTD.
(DESIGN DEPARTMENT)

PROJECT	UNIT	FORM	REVISED	SHEET	TOTAL
-	-	L S	000060	3 of 7	1

- 5.7 Girth flanges and tube sheets shall be in single piece, without any joint. Plates may be used for girth flanges and tube sheets up to & including thickness of 50 mm; above only ultrasonically tested forgings should be used. All carbon steel plates having thickness equal to or greater than 25 mm and alloy steel/stainless steel plates of thickness equal to or greater than 20 mm shall be ultrasonically tested as per applicable standards. All edges of plates in these thickness shall be magnetic particle/dye penetrant tested.
- 5.8 Each U-tube in case of U-tube exchanger, shall be formed from a single straight length. Before starting any bending of tubes, a mock-up test shall be carried out for inner most tube radius and get approved to establish all requirement of applicable code. Bent portion of tubes shall be dye penetration tested. After bending, U-tubes shall be hydro statically tested as per Code.
- 5.9 Tube to tube sheet weld joints shall be DP checked. In case of strength welded joints, welding shall be done in minimum two passes and each pass shall be DP checked. Mock up test shall be carried out establishing the torque requirement for achieving desired joint. The procedure and parameters for mock up tests, if necessary, shall be submitted for Authorized Agency/Owner's approval.
- 5.10 Minimum size of any nozzle opening shall be of 1.1/2" NB. Connections smaller than 1.1/2" NB shall be provided by welding 1.1/2" NB nozzle neck on equipment and shall be reduced to suitable nozzle size by providing a reducer welded to smaller size flange. Connection of this size shall be braced with 2 Nos. 6 x 30 size flats.
- 5.11 Tray/Demister/Filter Elements support rings, wherever applicable, shall be welded to the vessel shell with continuous welds, both at top & bottom. The bottom weld shall be designed as a strength weld and the weld on the top shall be a seal weld.
- 5.12 In case of stress relieved equipment, absolutely no welding, hammering, pressing or forming operation shall be performed without prior approval of the Owner/Authorized Agency.
- 5.13 Facilities and procedure to be followed for Heat Treatment/Stress Relieving shall be submitted by supplier for Authorized Agency/Owner's approval. Local stress relief shall be not be carried out before full details of the proposed method and technique have been reviewed in writing by the Authorized Agency/Owner.
- 5.14 The final machining of gasket seating faces shall be carried out after welding or any heat treatment have been completed.
- 5.15 THE MANHOLE COVER SHALL BE PROVIDED WITH DAVEY ARM/HINGE ARRANGEMENT AS PER OWNER'S STANDARD DRAWING ENCLOSED HEREWITH.**
- 5.16 THE TOLERANCES SHALL BE MAINTAINED AS PER APPLICABLE CODES AND AS PER OWNER'S STANDARD DRAWINGS ENCLOSED HEREWITH. WHEREVER APPLICABLE, MANUFACTURER'S STANDARDS MAY ALSO BE FOLLOWED. MORE STRINGENT TOLERANCES SHALL BE MAINTAINED.**
- 5.17 Tube sheet shall present a fiat surface within about +/- 1/32" after tube rolling/welding.



GUJARAT STATE FERTILIZERS & CHEMICALS LTD.
(DESIGN DEPARTMENT)

PROJECT	UNIT	FORM	NUMBER	SHEET	REV.
-	-	L S	0000160	4 OF 7	1

- 5.18 All external attachment welded directly with vessel/equipment to be of the same grade of material on which it is welded or the attachment shall be welded by providing a pad plate of the same grade of material on which it is welded.
- 5.19 Temporary attachments and their welds shall be of compatible material to that of the parent plate. They shall be kept to a minimum and removed by grinding or chipping followed by DP Testing and not by direct blows. Damaged areas shall be repaired by welding, dressed and restored to the condition of the parent plate.
- 5.20 Vessels that can not be transported in one piece, shall be shop fabricated to the largest size that can be transported leaving a minimum amount of field welding to be performed. This shall be decided in consultation with Owner/Authorized Agency. All edges for welding to be shop prepared and adequately protected against any damage during transportation to site.
- 5.21 Utmost care shall be taken by supplier to avoid contacts of iron particles with stainless steel surfaces during storage, fabrication, testing and transportation.

6.0 INSPECTION & TESTING

- 6.1 Owner may depute his inspector/Authorized Agency or may request bidder to engage a specific inspection agency to ascertain that equipment/material being supplied are in compliance with these specifications and relevant codes.
- 6.2 Within 10 days of order placement supplier shall submit a quality assurance plan indicating various inspection stages to be followed during fabrication. Against each such stage the name of Agency involved in inspection shall be mentioned.
Whenever Owner's presence is required supplier shall notify inspection call atleast ten days in advance.
- 6.3 Inspection shall be carried out during various stages of fabrication and before despatch and also for sub-ordered materials, if any :

Atleast following stage-wise inspection in addition to those required by Authorized Agency shall be carried out :

- i) Raw material identification
- ii) Qualification of welders as per approved welding procedure
- iii) Edge preparation
- iv) Alignment of longitudinal seams
- v) Alignment of circumferential seams
- vi) For heat exchanger, tubesheet drilling, grooving and alignment checking
- vii) Dye penetrant test of root runs
- viii) Radiographic evaluation
- ix) Heat treatment, wherever applicable
- x) Ultrasonic/magnetic particle examination wherever applicable

- 6.4 The equipment shall be radiographically inspected as specified in the data sheet. The radiographs shall be exhibited to inspector for examination whenever applicable. The extent of spot radiography shall be as under :



GUJARAT STATE FERTILIZERS & CHEMICALS LTD.
(DESIGN DEPARTMENT)

PROJECT	UNIT	FORM	NUMBER	SHEET	REV.
☐	☐	L S	000060	5 OF 7	1

- (a) All tee joints; plus
 - (b) 10% of total weld length
- Supplier shall carry out radiography on the spots decided by Owner's inspector/Authorized Agency.
- 6.5 Inspection reports for materials identification and stage-wise inspection shall be maintained by supplier's inspection agency.
 - 6.6 The inspection report of the dished end manufacturer shall be submitted to Owner/Authorized Agency and further fabrication work on dished end shall be started only after getting Owner's /Authorized Agency's approval.
 - 6.7 All reinforcement pad welds shall be pressure tested with air and soap solution at a pressure of 1.00 Kg/cm²g before hydro static test.
 - 6.8 The equipment shall be hydro statically tested at supplier's shop as per the code requirement in presence of Owner's inspector/Authorized Agency.
 - 6.9 The test liquid shall be potable water unless otherwise specified. DM water shall be used for hydro static testing of stainless steel vessels. After testing, vessel shall be thoroughly cleaned and dried.
 - 6.10 Supplier shall ensure that gaskets or joint rings on all flanges, during pressure test, shall be of the same material and that of the same dimensions as those specified for the operating duty.
 - 6.11 In case of agitated vessels, a running trial with water shall be taken in presence of Owner's inspector/Authorized Agency.
- 6.12 WHEREVER APPLICABLE, PICKLING AND PASSIVATION, SHALL BE DONE BEFORE DESPATCH OF STAINLESS STEEL EQUIPMENT AS PER OWNER'S STANDARD SPECIFICATIONS ENCLOSED HEREWITH.**

DRAWINGS & DOCUMENTS

- 7.1 On completion of order, supplier shall submit six sets of "As Built" GA/Fabrication drawing alongwith details of Bill of Material and one set of original tracings and floppy disk. Supplier shall also submit the following as final documents; in triplicate,
 - i) Material test Certificates showing chemical analysis and physical properties of all major components.
 - ii) Final inspection reports for each equipment.
 - iii) Furnace temperature charts for heat treated vessels
 - iv) Hydrostatic test report
 - v) Rub off
 - vi) Any other documents as required
- 7.2 The following information on each document must be incorporated while sending the same to the Owner:
 - (a) Drawing number with revision code
 - (b) Item number and description
 - (c) Purchase Order no. and date
 - (d) Material Requisition no. (MR no.)
 - (e) Location/Plant of the Unit
 - (f) Purchaser/Supplier's full name
 - (g) Total weight of the equipment in empty, full of water and operating condition.



GUJARAT STATE FERTILIZERS & CHEMICALS LTD.
(DESIGN DEPARTMENT)

PROJECT	UNIT	FORM	REVISION	SHEET	NO.
-	-	L 5	000060	6 OF 7	1

7.3 All the drawings shall be prepared in INK, to the scale and with maximum size restricted to A1.

8.0 PAINTING :

8.1 Prior to painting of equipment, all surfaces shall be thoroughly de-scaled and cleaned. The surface shall be dry and free from rust, scale, sharp points, weld spatters, oil, grease and any other foreign materials before paint is applied.

8.2 The external unmachined CS surface of equipment shall be painted with two coats of rust preventive Red Oxide Zinc Chromate Primer for design temp. less than or equal 75 deg. C. For equipment having design temperature higher than 75 deg. C, one coat of heat resisting aluminium paint shall be applied.

8.3 The total dry film thickness shall be 1.0-1.5 mils for primer.

9.0 GURANTEE :

9.1 Supplier shall guarantee the equipment and its components including internals against improper material of construction and poor workmanship for a period of 18 months after the equipment is put in service, or 30 months after despatch of equipment from supplier's works for 30 months from handing over the equipment after successful testing in case of equipment fabricated / assembled at site, whichever is earlier.

9.2 Should any repair or replacement be necessary owing to any type of failure on account of material of construction and workmanship of the equipment and / or its internals during the guarantee period, the supplier shall by dint of this guarantee be bound to replace the same either in part or in full without any additional cost. Repaired or replaced parts shall also be covered by same guarantee as in the case of main supply. Repair/replacement job shall be completed on priority without holding up work and date mutually agreed with owner.

10.0 PACKING/FORWARDING/DESPATCH :

10.1 Goods shall be securely packed to withstand all hazards in transit upto destination. Two copies of packing list mentioning net weight of goods shall be sent alongwith packing boxes.

10.2 All nozzle openings shall be blinded securely with appropriate wooden blanks while despatch to avoid ingress of any foreign material inside the equipment till it is erected at site.

10.3 After despatch of goods, the supplier shall inform despatch particulars immediately by FAX to take care of transit insurance formalities, as transit risk is to be covered by the owner.



GUJARAT STATE FERTILIZERS & CHEMICALS LTD.
(DESIGN DEPARTMENT)

PROJECT	UNIT	FORM	NUMBER	SHEET	REV.
-	-	L 5	000060	7 OF 7	1

1.0 SCOPE :

This specifications defines the requirements for the selection and application of paints (including primers) on exposed surfaces as stated below :

- a) All structural steel work, walk ways, ladders etc. which have not been galvanised;
- b) All the insulated as well as uninsulated carbon and low alloy steel piping and equipment.

The nonferrous materials, stainless steel and plastic and/or plastic coated materials are not to be painted. Δto

2.0 CODES AND STANDARDS :

The following codes will be used in connection the paints and the related work:

- IS- 5 - Colour for ready mixed paints
- IS- 101 - Method of test for ready mixed paints and enamels;
- IS- 158 - Specifications for ready mixed paints brushing bituminous black lead free, acid, alkali, water and heat resisting for general purposes;
- IS- 363 - Ready mixed paints, exterior, general purpose;
- IS- 1477 - Code of practice for painting;
- IS- 2074 - Specifications for ready mixed paint red oxide zinc chrome priming;
- IS- 2339 - Aluminium paints
- IS- 2379 - Colour code for the identification of the pipelines;
- IS- 2932 - Specifications forenamel, exterior type-I
 - a) Under coating
 - b) Finishing colour as required

3.0 SURFACE PREPARATION :

3.1 General :

- 3.1.1 Durability of painting depends upon method of surface preparation. If painting is done over mill scale, rust scale and other contamination such as grease and oil, the duration of protective painting is decreased sharply. Maximum durability can be achieved by adopting one of the following surface preparation methods.

DESIGN & CONSTRUCTION
DEPARTMENT

GUJARAT STATE FERTILIZERS CO. LTD.

DESIGN & CONSTRUCTION DEPARTMENT

SPECIFICATIONS FOR PAINTING

PROJECT	UNIT	FORM	NUMBER	SHEET	REV
00	00	SP	23001	1	1

1. Hand cleaning
2. Power tool cleaning
3. Blast cleaning

3.1.2 The selection of surface preparation method shall depend upon the condition of steel surface and shall be decided as per the recommendation of paint manufacturer.

3.1.3 Where surface preparation by hand cleaning or power tool cleaning is applied, the first coat shall be painted with brush as a rule.

3.2 Procedure of surface preparation :

3.2.1 Surface preparation by hand cleaning consists of
 (a) hand descaling and/or hammering; (b) hand scraping
 (c) hand wire brushing.

Rust, mill scale spatters and other foreign matter shall be removed by hammering, scraping with scraping tools or emery, wire brushing or combination of the above methods on completion of cleaning, loose material shall be removed from the surface.

3.2.2 Power tool cleaning :

Power tool cleaning shall be done by mechanical striking tools, chipping hammers, grinding wheels or rotating steel wire brushes. Excessive brushing of the surface shall be avoided as it can reduce paint adhesion. On completion of cleaning, the detached rust mill scale etc. shall be removed by clean rags or washed by water or steam and thoroughly dried before application of the paint.

3.2.3 Blast cleaning :

The surfaces shall be blast cleaned using one of the abrasives like sand or chilled cast iron or malleable iron and steel. Compressed air should be free from moisture and oil. On completion of sand blasting, the blasted surface shall be cleaned and freed from any scale or rust and must show a grey white metallic luster. Primer or first coat of paint shall be applied, within 4 hours of surface preparation by sand blasting. Blast cleaning shall be done outdoors in bad weather without adequate protection nor when there is dew on the metal or at the nozzle during the work.

3.2.4 Rub down and touch up of primer :

Surfaces, if shop coated, shall be thoroughly rubbed down with emery paper to remove all dust, rust and other foreign matters, washed with degreasing solvent -

GUJARAT STATE FERTILIZERS CO. LTD. DESIGN & CONSTRUCTION DEPARTMENT	SPECIFICATIONS FOR PAINTING					
	PROJECT	UNIT	FORM	NUMBER	SHEET	REV
	00	00	57	23001	27	1

- (white spirit) to remove grease, etc. Then cleaned with warm fresh water and dried. The portions where the shop coat has peeled off, shall be touched up and allowed to dry before giving first coat of anticorrosive primer.

3.2.5 Strapping off primer and manual preparation :

If shop coat is provided as rust inhibitor, but is incompatible with finishing paint, then it shall be removed completely by suitable mechanical or chemical means (wherever desired but shall subsequently be neutralized) and washed with hot water, soon after the bare surface has dried, primer shall be applied.

3.2.6 Trace of mill scale and loose rust shall be removed by different mechanical means like steel wire brushing, emery paper, chipping, hammering and grinding followed by detergent bath of the bare surfaces and rinsed thoroughly with warm fresh water. After the surface is cleaned and dry primer coat shall be applied.

4. Materials :

1 - Primers

P-1 - Zinc chromate/zinc phosphate :

Composition : Zn chromate/zn phosphate pigmented in alkyd/phenolic medium.

Max. operating temp. : 30 - 35°C.

Application : Suitable for brush application

Colour : Grey

P-2 - Zinc chromate/zinc phosphate :

Composition : Zinc chromate/phosphate pigmented in epoxy.

Max. op. temp. : 70 - 75°C.

Application : Suitable for brush application.

Colour : Grey

P-3 - Red Oxide-zinc chromate :

Composition : Red Oxide-zinc chromate pigmented in alkyd/phenolic media.

Max. Op. temp. : 70 - 75°C.

Colour : Grey

Application : Suitable for brush application.

GUJARAT STATE FERTILIZERS CO. LTD.

DESIGN & CONSTRUCTION DEPARTMENT

SPECIFICATIONS FOR PAINTING

PROJECT	UNIT	FORM	NUMBER	SHEET	REV
00	00	SP	23061	3	7

P-4 : Zn rich.
 Composition : Metallic zinc pigmented in epoxy.
 Max.op.temp. : 70 - 75° C
 Application : Suitable for brush application.
 Colour : Grey.

II. Finishing Coats :

F-1 : Synthetic enamel :
 Composition : Suitably pigmented high glass alkyd/phenolic media with excellent flow and quick drying properties, offering outstanding resistance under varying weather conditions.

Max.op.temp. : 70 - 75° C
 Application : Suitable for brush application.
 Colour : Grey

F-2 : Epoxy Paint :
 Composition : Suitably pigmented epoxy polyamide combination offering superior resistance to acids and moisture.

Max.op.temp. : 70 - 75° C.
 Application : Suitable for brush application.
 Colour : Grey.

F-3 : Coal tar epoxy :
 Composition : Epoxy resin coal tar blend.
 Application : Suitable for brush application.
 Max.op.temp. : 70 - 75° C.
 Colour : Black or brown

F-4 : Chlorinated rubber paint :
 Composition : Suitably pigmented plasticised chlorinated rubber medium.
 Application : Suitable for brush application.
 Max.op.temp. : 65° C
 Colour : Grey.

GUJARAT STATE FERTILIZERS CO.LTD. DESIGN & CONSTRUCTION DEPARTMENT	SPECIFICATIONS FOR PAINTING					
	PROJECT	UNIT	FORM	NUMBER	SHEET	REV
	00	00	5 P	23001	4	3

F-5

: Aluminium Paints ;
(Primer not required)

i) Heat resisting aluminium paint capable of withstanding temperature upto 250° C.

Composition : Heat resisting special varnish medium combined with leafing aluminium.

Application : Suitable for brush application

Colour : Aluminium

ii) a) Heat resisting aluminium paint capable of withstanding temperature from 250° C to 400° C.

b) Heat resisting aluminium paint capable of withstanding temperature from 350° C to 500° C.

c) Heat resisting aluminium paint capable of withstanding temperature from 450° C to 600° C.

Composition : Aluminium paint based on modified or straight silicone.

Application : Suitable for brush application.

Colour : Aluminium.



GUJARAT STATE FERTILIZERS CO. LTD.

DESIGN & CONSTRUCTION DEPARTMENT

SPECIFICATIONS FOR PAINTING

PROJECT	UNIT	FORM	NUMBER	SHEET	REV
02	02	SP	23001	57	1

P A I N T I N G S C H E D U L E

Sr. No.	Description	Max. temp.	Shop Painting i.e. Primer (1 to 1.5 mills) one coat	Cleaning/ surface preparation	Field Painting			Min. dry film thk.
					Primer (1 coat) (1 - 1.5 mills)	Finishing Paint (two coats)		
1. A) Non-Corrosive Area :								
1. Static equipment (columns, vessels, exchangers, motors, control panels, transformers, etc.)								
	a) Non-insulated item	70-75°C	P-1 or P-3	Note - II	-	F - I		5 Mills
	b) Hot insulated item	600°C	*  P-3	Note - I	-	F-5(i) or (ii) depending upon temp.		3 Mills
	c) Cold insulated items	-	P - 3	Note - II	-	-		-
2. <u>Piping :</u>								
	a) Non-insulated	70-75°C	-	Note - I	P-1 or P-3	F - I		5 Mills
		600°C	-	Note - I	-	F-5(i) or (ii) depending upon temp.		3 Mills
	b) Hot insulated	600°C	-	Note - I	-	- do -		3 Mills
	c) Cold Insulated	-	-	Note - I	P - 3	-		1 - 1.5 Mills
	3. Machinery, (pump, compressors, blowers, etc.)	70-75°C	P-1 or P-3	Note - II	-	F - 1		5 Mills
	4. Structures (structural steel, pipe racks, platforms, hand-rails etc.)	-	-	Note - I	P-1 or P-3	F - 1		5 Mills
	5. Furnace & connected stack.	600°C	*  P-3	Note - I	-	F-5(i) or (ii) depending upon temperature.		3 Mills

Note:

 * By vendor. Suitable for transportation and weather protection during transportation.

GUJARAT STATE FERTILIZERS CO. LTD.									
DEN	10/12/79								
CHD									
APP	11/2/79								
1	6/9/79	REVISED AS							
0	11/2/79								
REV	DATE	DESCRIPTION	CHD.	APP.	0	0	0	0	5
					2	3	0	0	1

**SPECIFICATIONS FOR
P A I N T I N G**

0 0 0 0 5 P 2 3 0 0 1 6 0 1 2

Sr. No.	Description	Max. Temp.	Shop Painting i.e. Primer (1 to 1.5 mills) one coat	Cleaning/ surface preparation	Field Painting		Min. dry film thk.
					Primer (1 coat) (1 - 1.5 mills)	Finishing Paint (two coats)	
2. B. CORROSIVE AREA :							
1. Static equipment columns, vessels, exchangers motors, control panel switch boxes, site fabricated tanks)							
a) Non-insulated		70-75°C	P-2 or P-4	Note - II	-	F-2 or F-4 **	5 Mills
		600°C	P-1 or P-3	Note - I	-	F-5(i) or (ii) depending upon temperature.	3 Mills
b) Hot-insulated		600°C	*	Note - I	-	- do -	3 Mills
c) Cold insulated		-	P - 3	Note - II	-	-	-
2. Concrete work or steel immersed in acidic media.		-	P-1 or P-3 (for steel)	Note - I	P-4	F - 3	5 Mills
3. Machinery (Pumps, compressors, blowers, etc.)		70-75°C	P-2 or P-4	Note - II	-	F-2 or F-4	5 Mills
4. Structures (structural steel work, pipe racks, handrails, platforms, etc.)		-	-	Note - I	P-2 or P-4	F-2 or F-4	5 Mills
5. Furnace and connected stack.		600°C	*	Note - II	-	F-5(i) or (ii) depending upon temp.	3 Mills

NOTE :

- Removal of earlier coating if any, or existing loose milscale rust, etc. by means of rotary wire brushes, or mech. wire brushing followed by sand preparing and degreasing. In case of site fabricated tanks surface, preparation will be by sandblasting.
- Touching up of existing coat of shop primer if the film has been damaged.
- In case of insulated piping, the colour bands for identification of the fluid inside the pipe should be applied over the GI/Aluminium sheetings provided over the insulating material.

* By vendor. Suitable for transportation and wheather protection during transportation.

GUJARAT STATE FERTILIZERS CO. LTD.

SPECIFICATIONS FOR PAINTING

REVISED AS	DATE	DESCRIPTION	CHD.	APP.
6/11/79	4/12/76			

CHD	APD	SCALE

NO.	DATE	DESCRIPTION	CHD.	APP.
0	4/12/76			

FORM	NUMBER	SHEET	REV
0	29001	7 OF 7	1

General Specifications for Pickling & Passivation

(A) "Cleaning" :

Clean surface and remove all extraneous matter with a hard fibre brush or SS wire brush. M.S. wire brush shall not be used. All organic materials shall be removed with any paint remover like light solvent naphtha or benzene or equivalent. Motor petrol shall not be used.

(B) "Pickling" :

Aqueous pickling solution shall be as follows :

Nitric Acid (Tech. grade) 10 to 25% plus Hydrofluoric acid 1 to 8% (to be used only for stabilised S.S. grades) Temperature 50 to 60 degrees C for 10% Nitric Acid and 20 degrees C for 25% Nitric Acid. When size and shape of product permit, total immersion in the pickling solution is preferred. Where immersion is impractical pickling may be accomplished by wetting the surface by

- 1) swabbing or spraying OR
- 2) by partial filling the item with pickling solution and rotating or rocking, so that all the surface receive the required chemical treatment.

The maximum period for which the pickling solution shall be allowed to remain on the surface is 30 minutes. During pickling, removal of oxides may be hastened by brushing with a hard fibre or S.S. wire brush. Over pickling shall be avoided.

The pickling agent shall be washed off with plenty of water so as to leave no trace behind.

(C) "Passivation" :

After pickling and water rinsing, an aqueous caustic permanganate solution containing NaOH 10% by weight and KMnO4 4% by weight shall be used for neutralising pickling solution. This shall be followed by thorough water rinsing.

Water used for pickling and washing shall not have chloride content exceeding 30 ppm.

	0	25.12 85	REVIEWED & UPDATED		
REV.	DATE	DESCRIPTION		CHD.	APP.
PROJECT	UNIT	FORM	NUMBER	SHEET	REV.
□□	□□	□□	□□□□	□□	□□

GUJARAT STATE FERTILIZERS CO. LTD.
 P.O. FERTILIZERNAGAR DIST. BARODA
 DESIGN DEPARTMENT